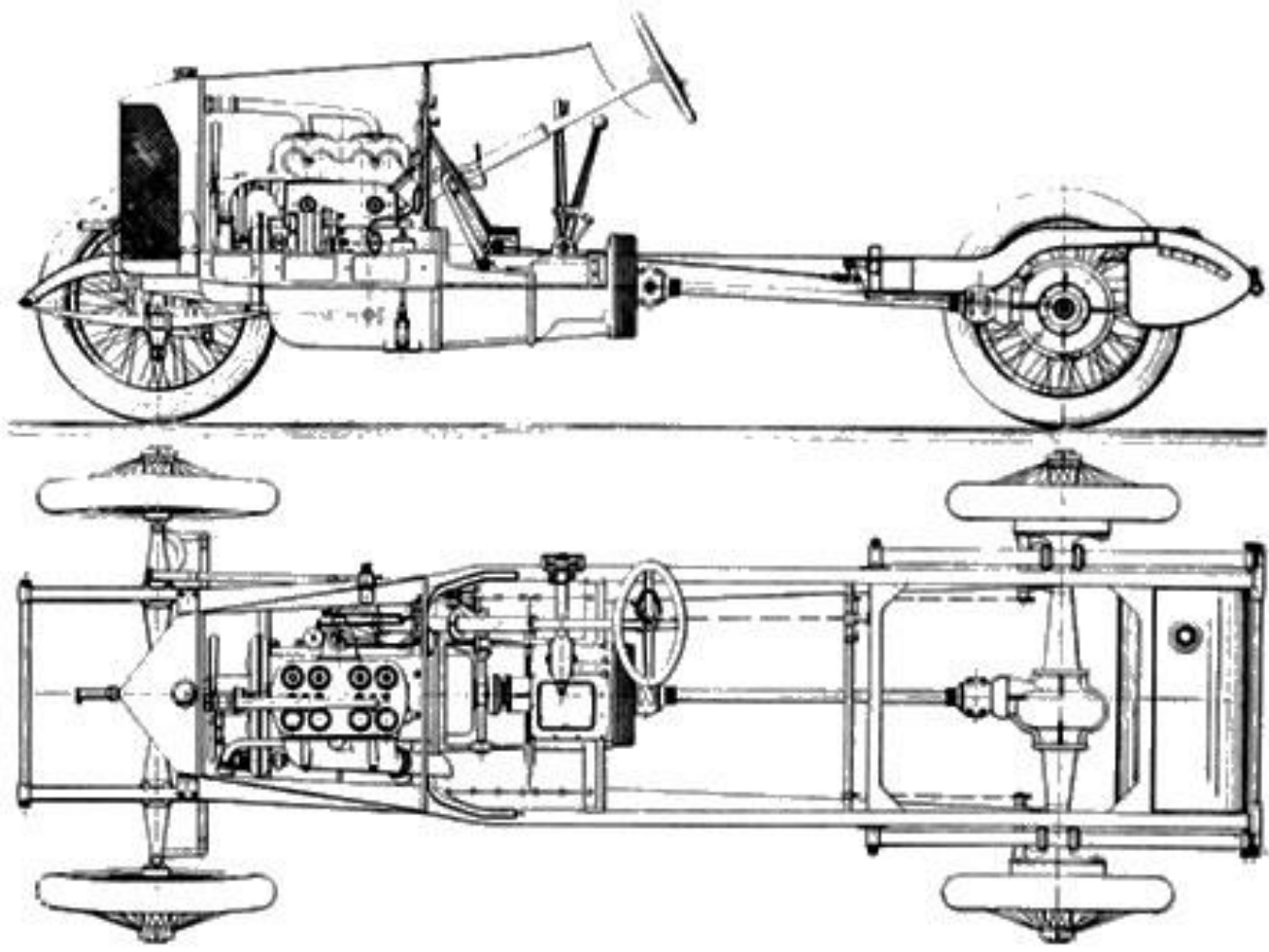


Exam of  
MECA0063 - Vehicle Architecture  
and Components

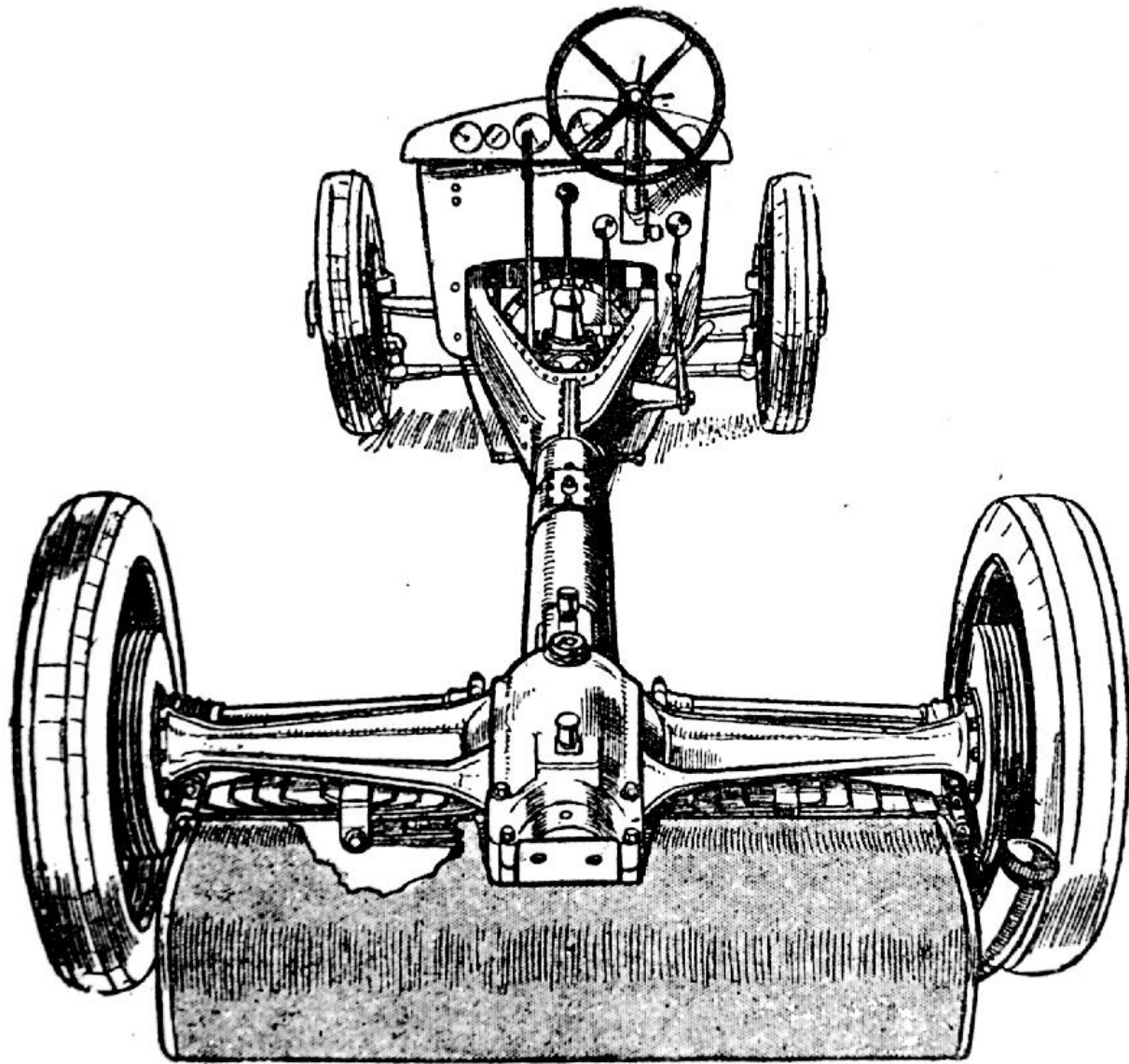
Academic year 2021-2022













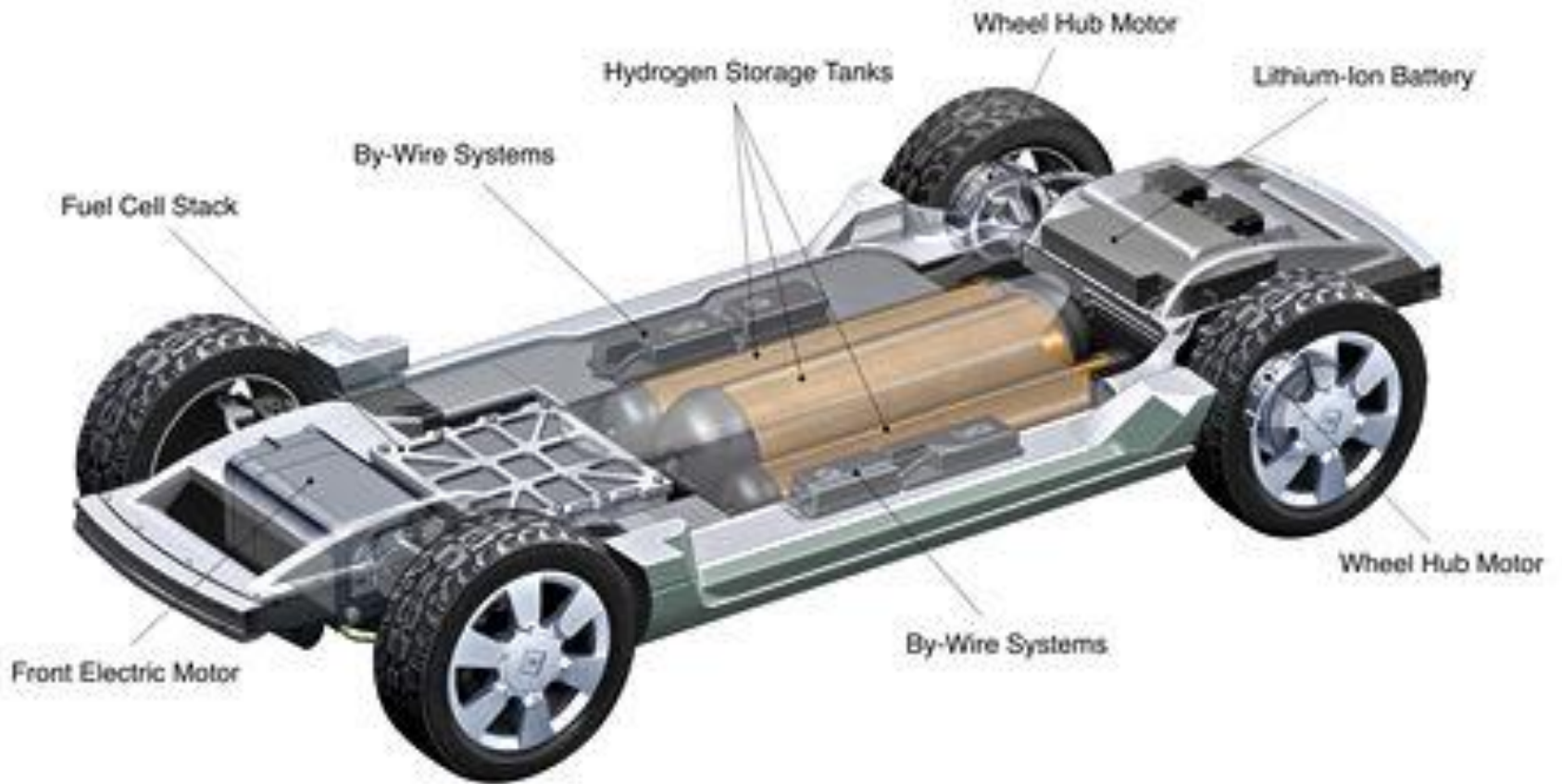
# Audi Q5

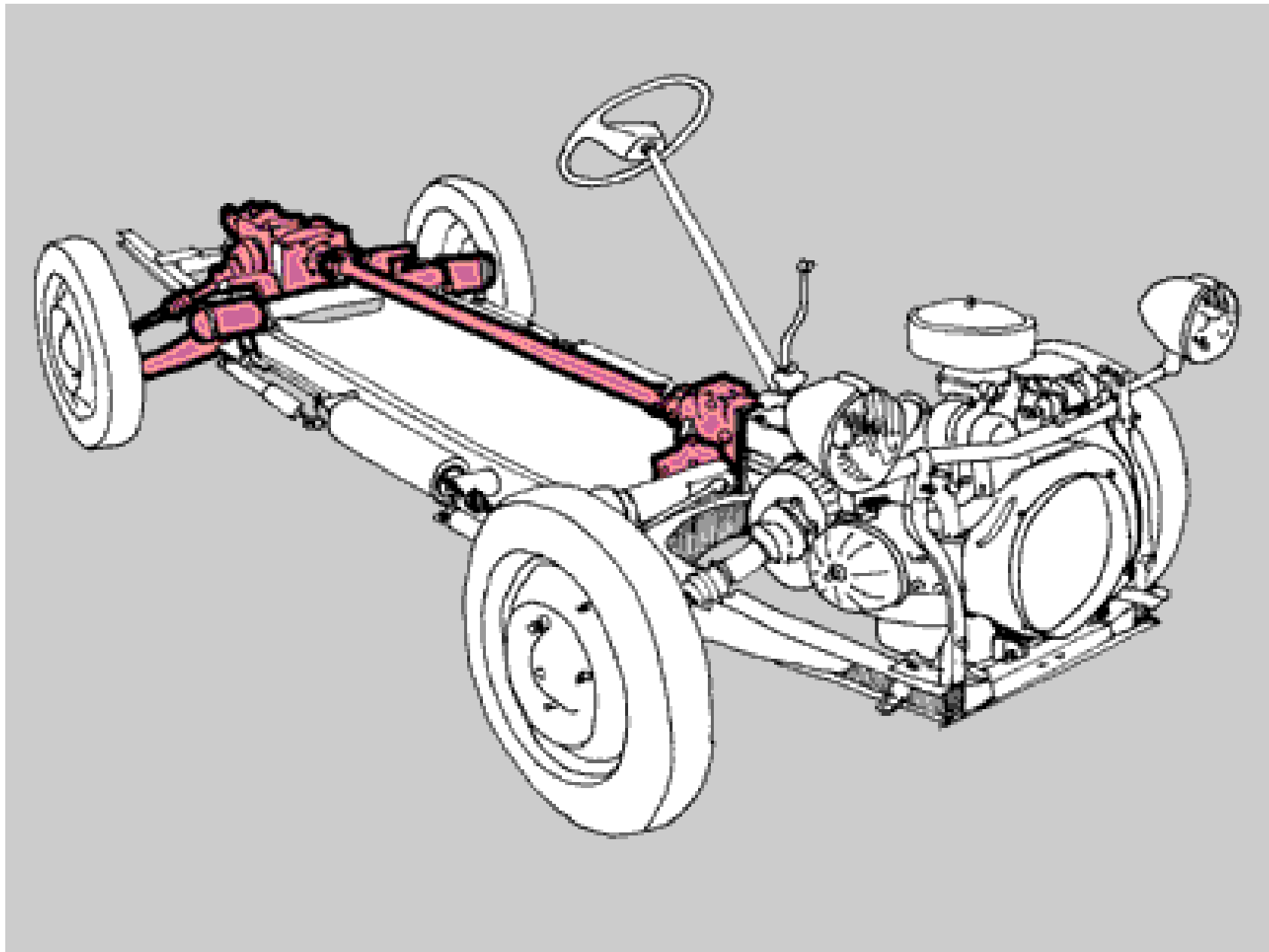
## Karosserie

Body structure

07/08









**turbo**  
ALL-WEATHER TURBOCHARGERS • IMPORTS • DOMESTIC • STREET • RACE RACING  
& HIGH-TECH PERFORMANCE





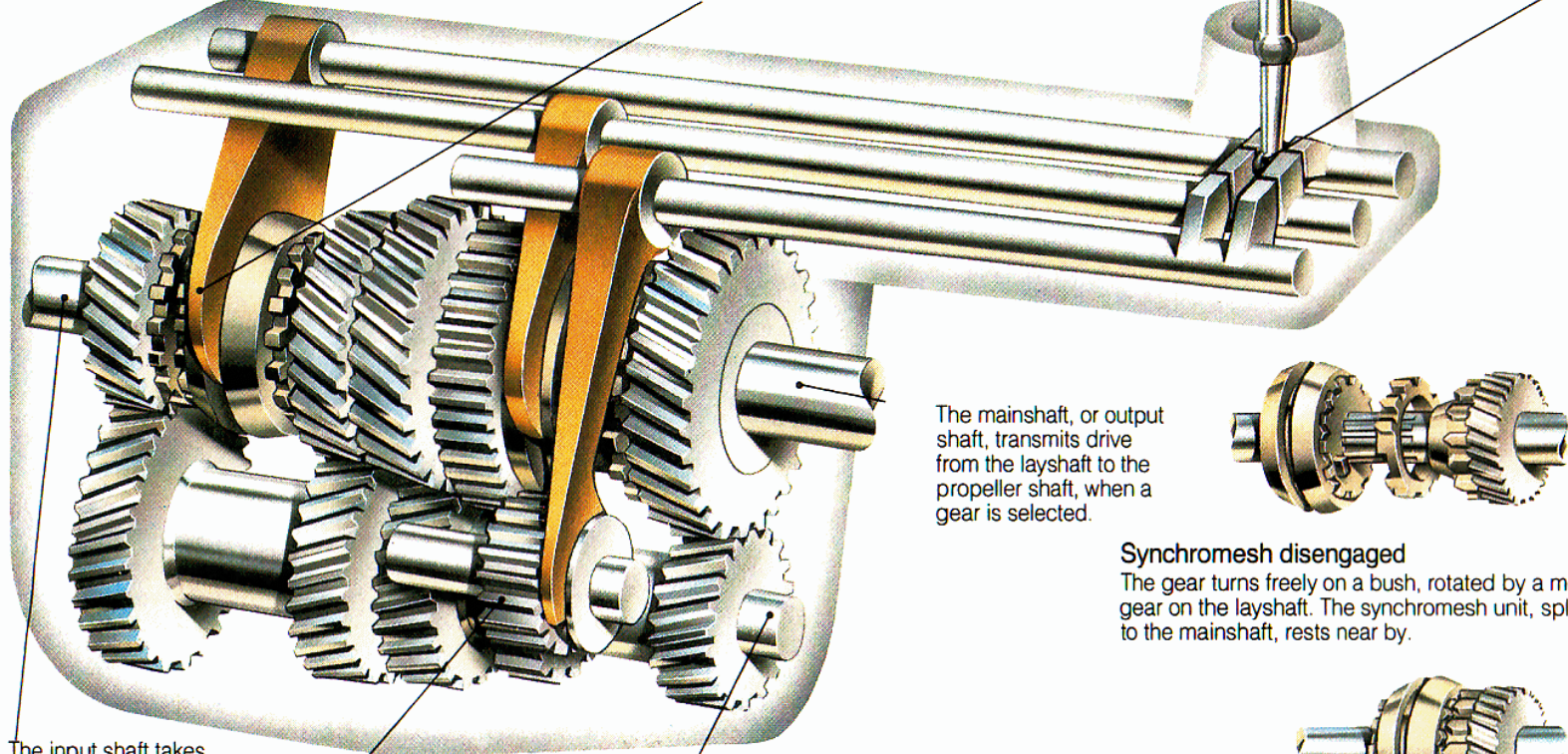
dreamstime.com

## A simple 4-speed constant mesh gearbox as used on RWD vehicles

The gears are selected by a system of rods and levers operated by the gear lever. The drive is transmitted through the input shaft to the layshaft gear (cluster gear) and then to the mainshaft, except in direct drive – top gear – when the input shaft and the mainshaft are locked together.

The selector rods and forks move the synchromesh units back and forth, according to which gear is selected. Some gearboxes have only one selector rod, others three; but the principle is the same.

A spring-loaded ball at the base of the gear lever aligns with a recess in the selector rod, holding the lever in position until the driver changes gears.



The input shaft takes the drive from the engine (when the clutch is engaged) into the gearbox.

When the reverse idler gear is selected, it is interposed in the gear train, reversing the normal direction of the mainshaft.

The layshaft transmits drive from the input shaft to the mainshaft, when a constantly meshed gear is locked to the mainshaft by means of a splined synchromesh.

The mainshaft, or output shaft, transmits drive from the layshaft to the propeller shaft, when a gear is selected.

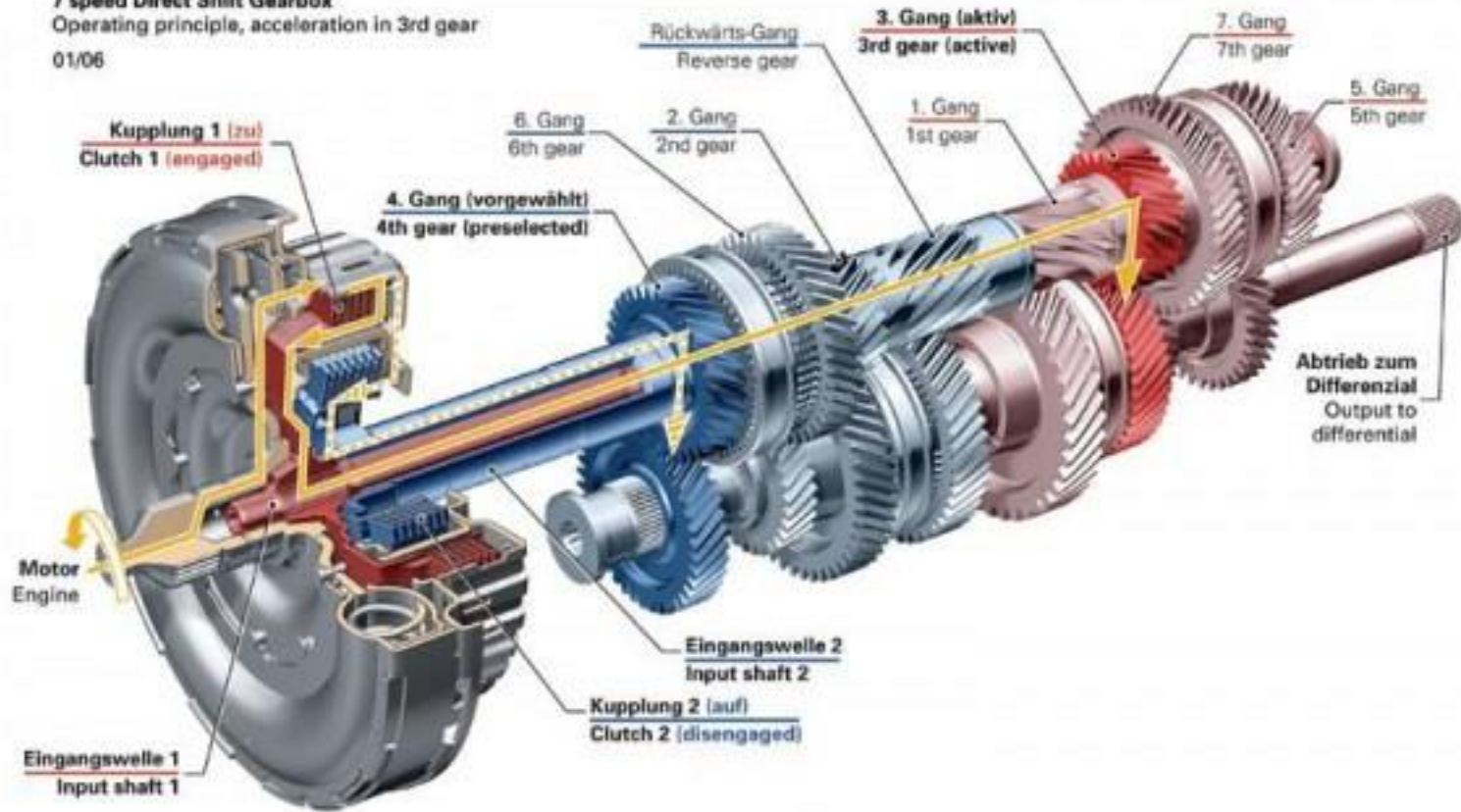
### Synchromesh disengaged

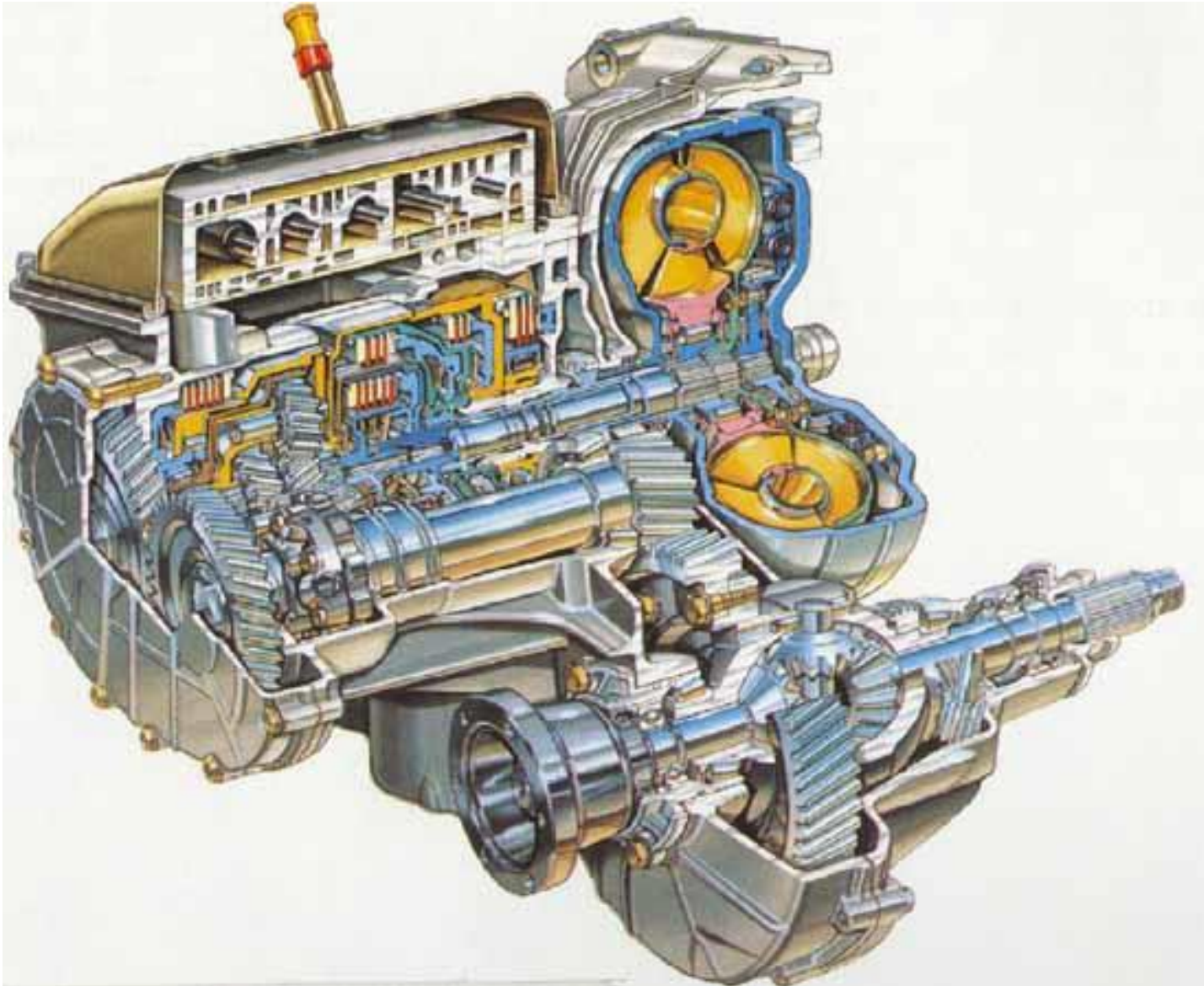
The gear turns freely on a bush, rotated by a meshing gear on the layshaft. The synchromesh unit, splined to the mainshaft, rests near by.

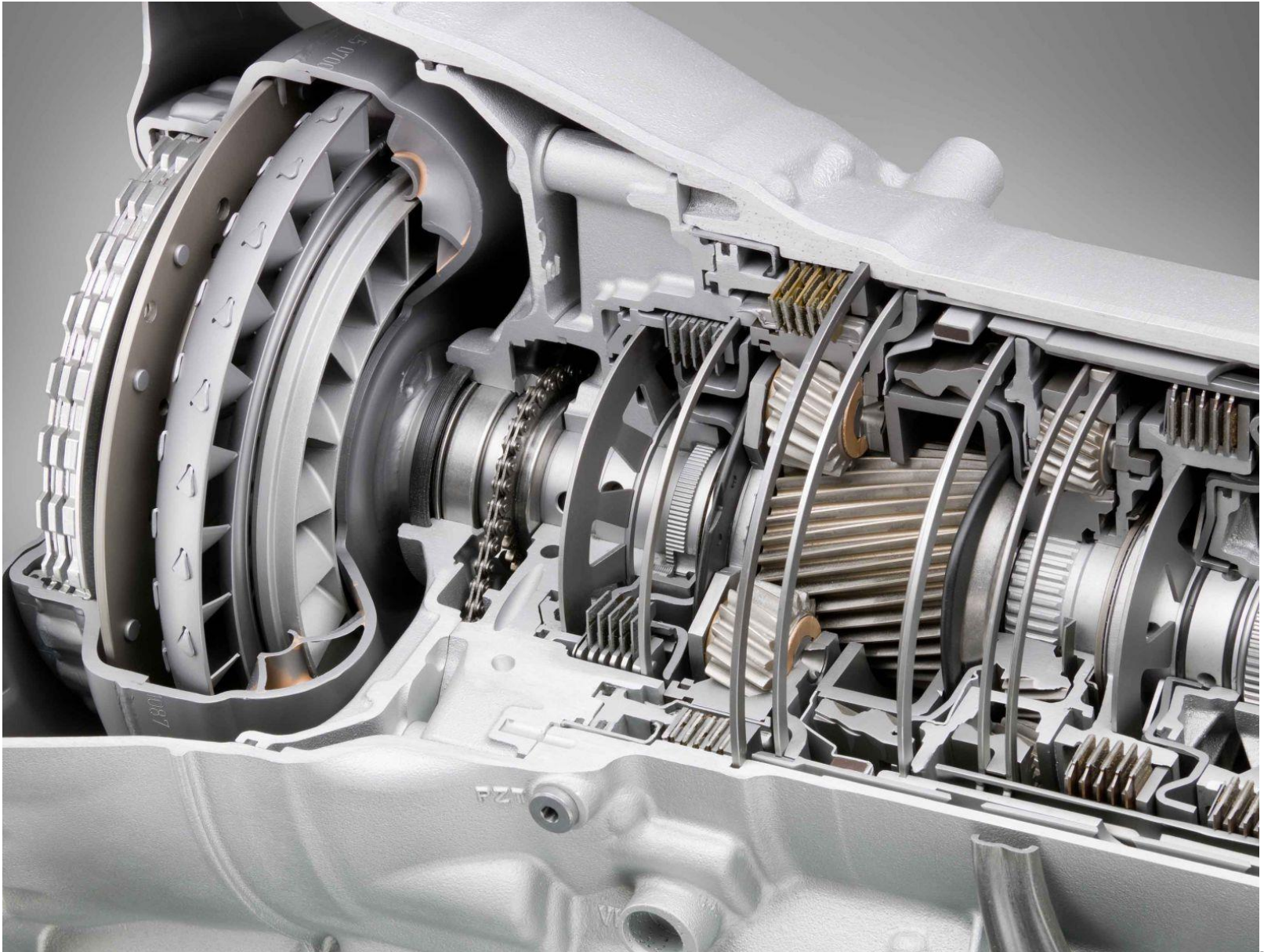
### Synchromesh engaged

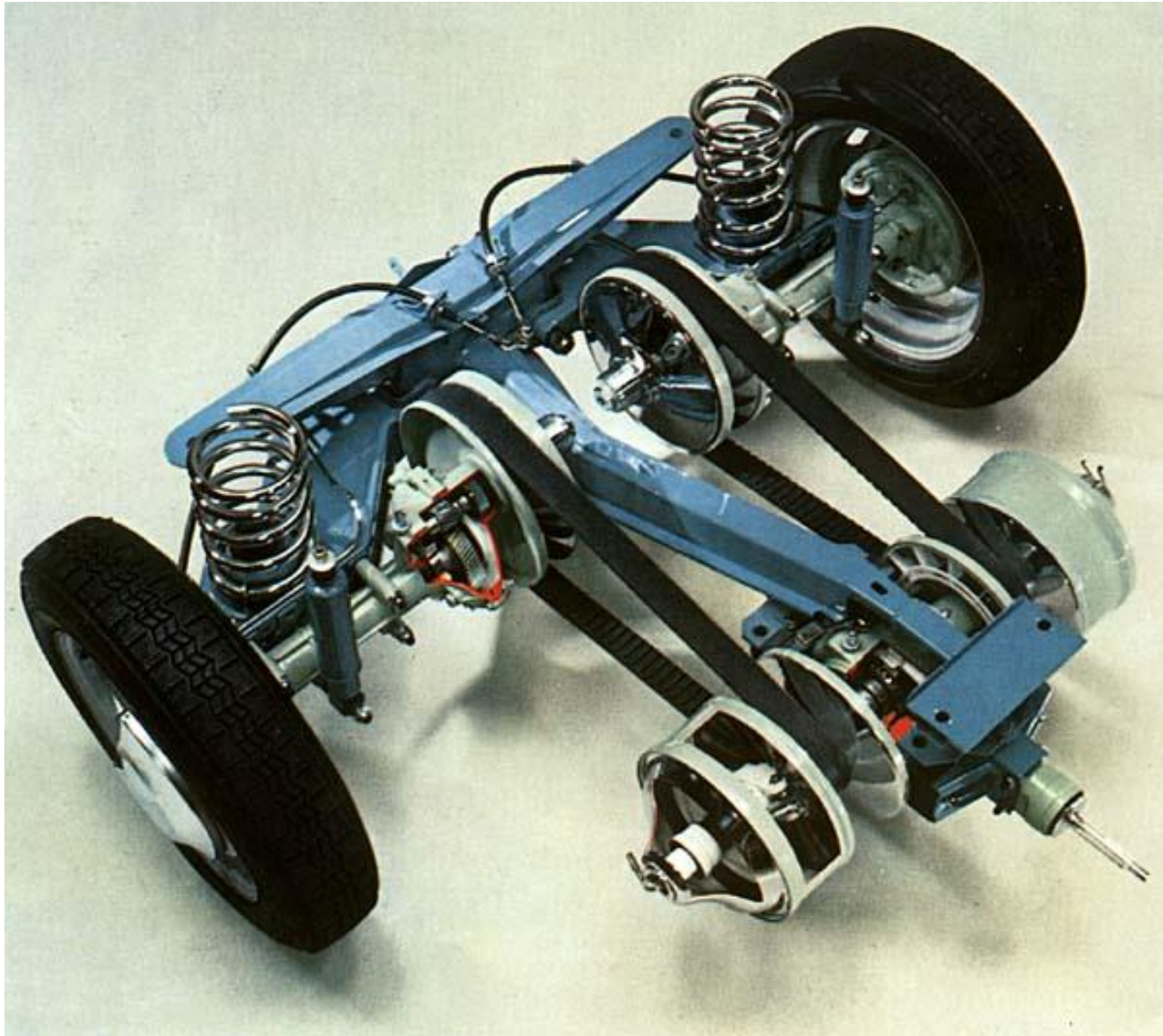
The fork moves the synchromesh towards the selected gear. Friction surfaces synchronise the shaft speeds, and synchromesh and gear lock together.

**7-Gang-Direktschaltgetriebe**  
 Funktionsprinzip, Beschleunigung im 3. Gang  
**7 speed Direct Shift Gearbox**  
 Operating principle, acceleration in 3rd gear  
 01/06

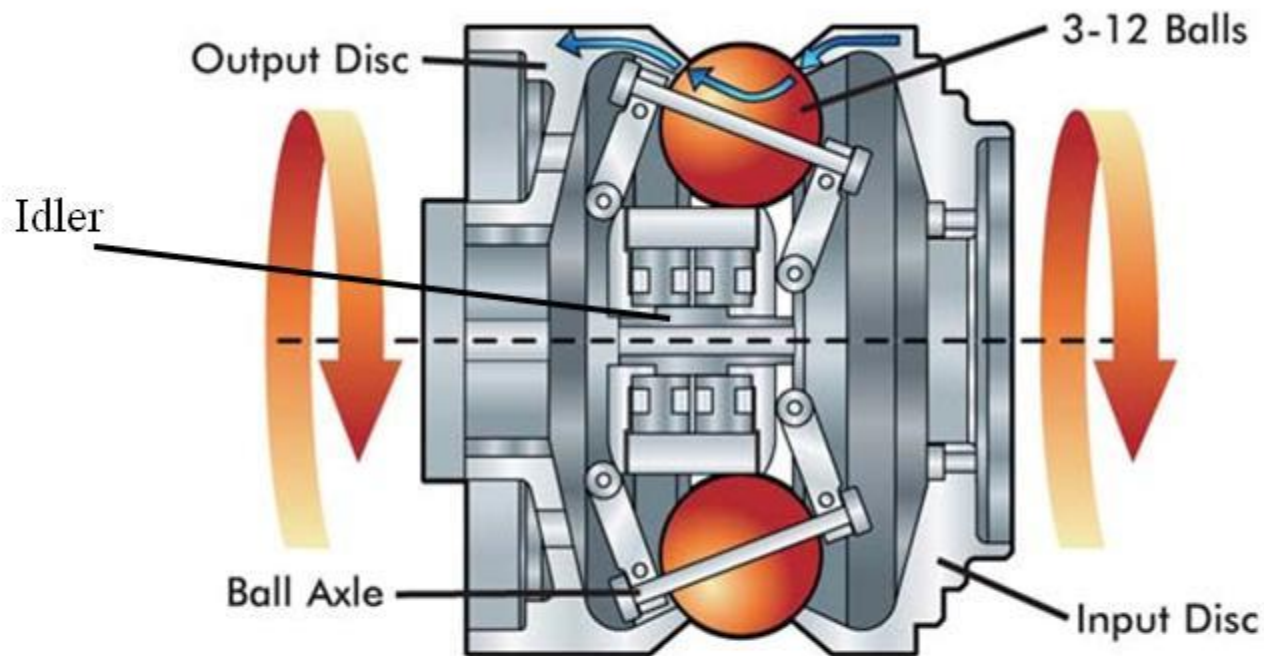




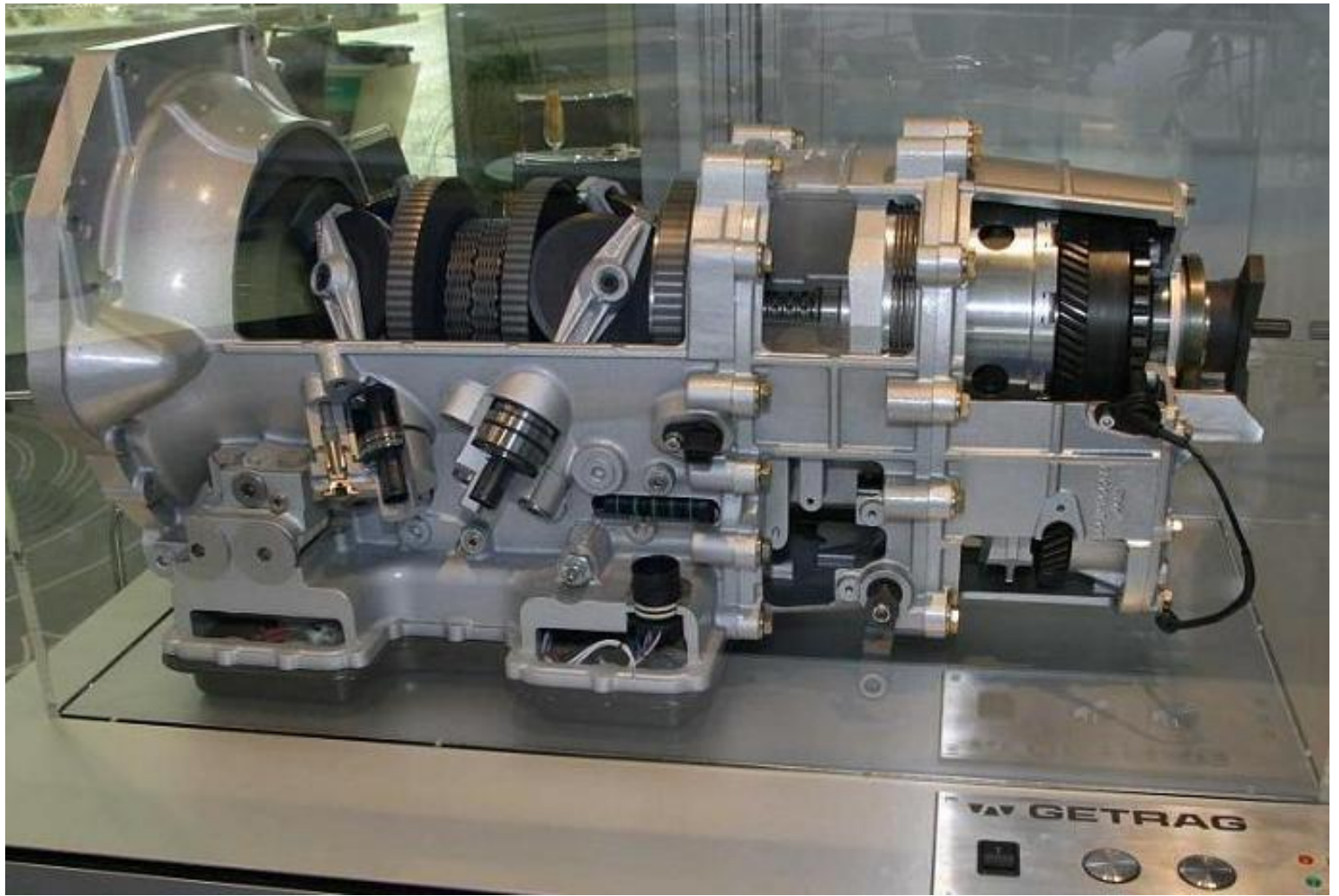


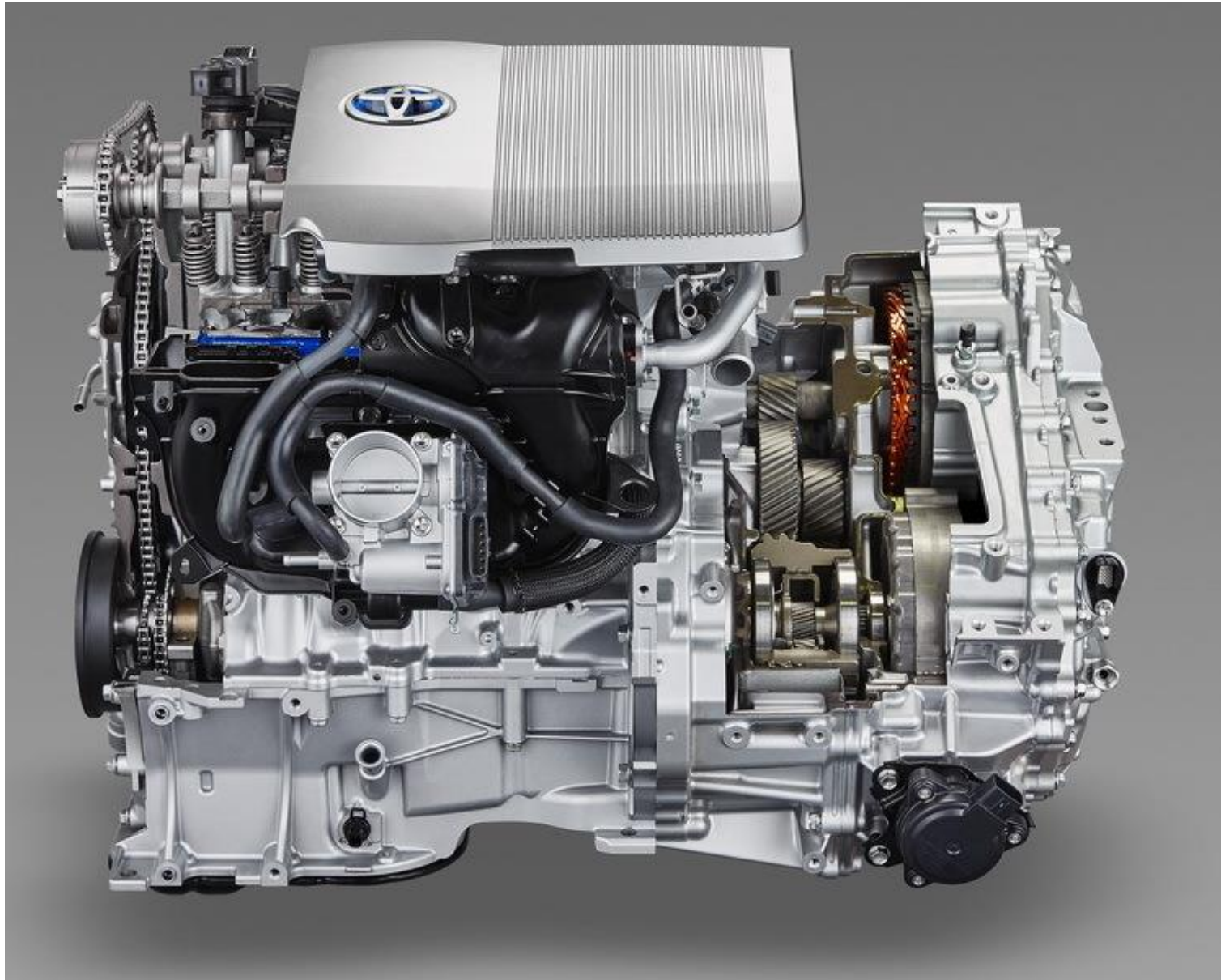




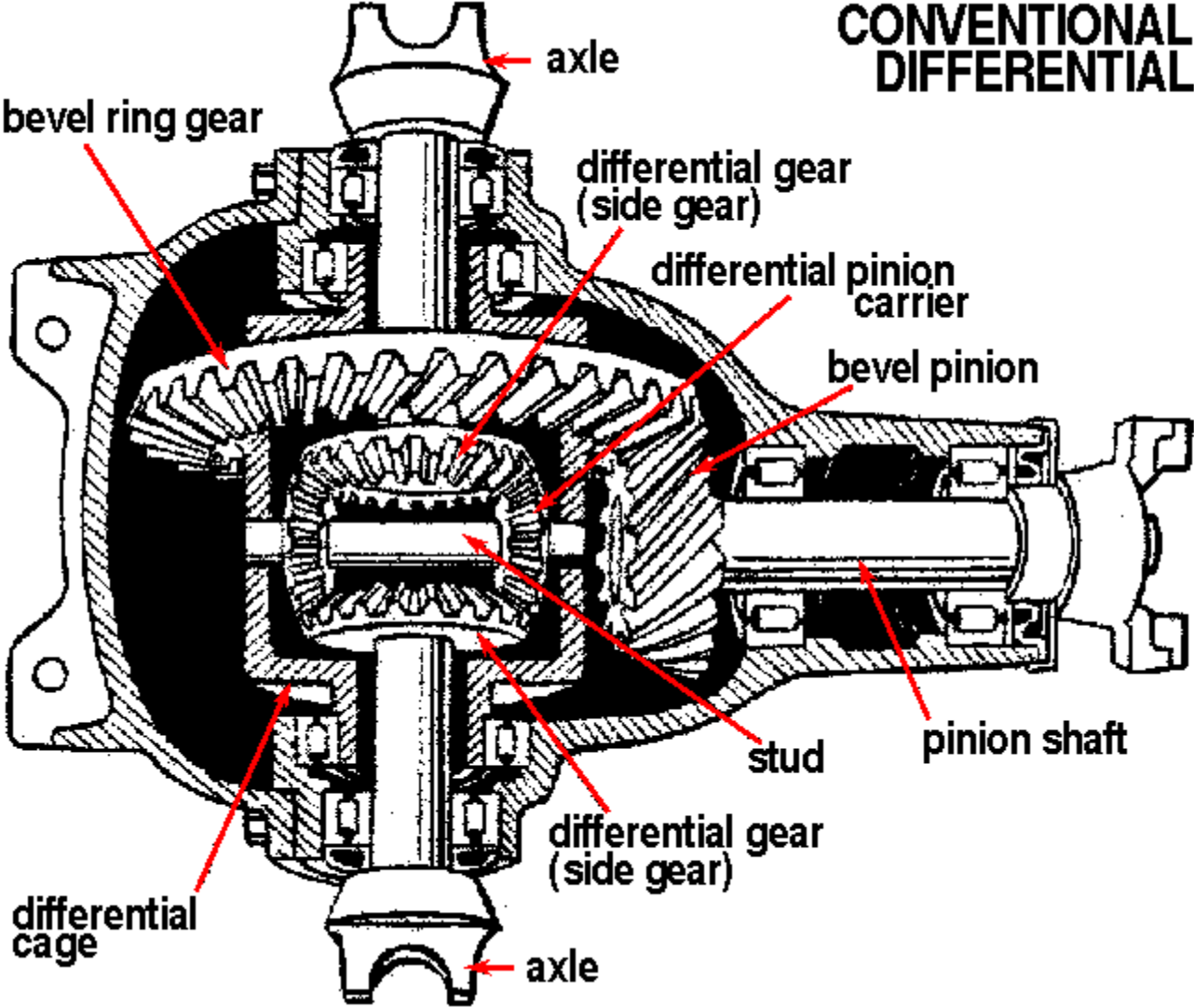


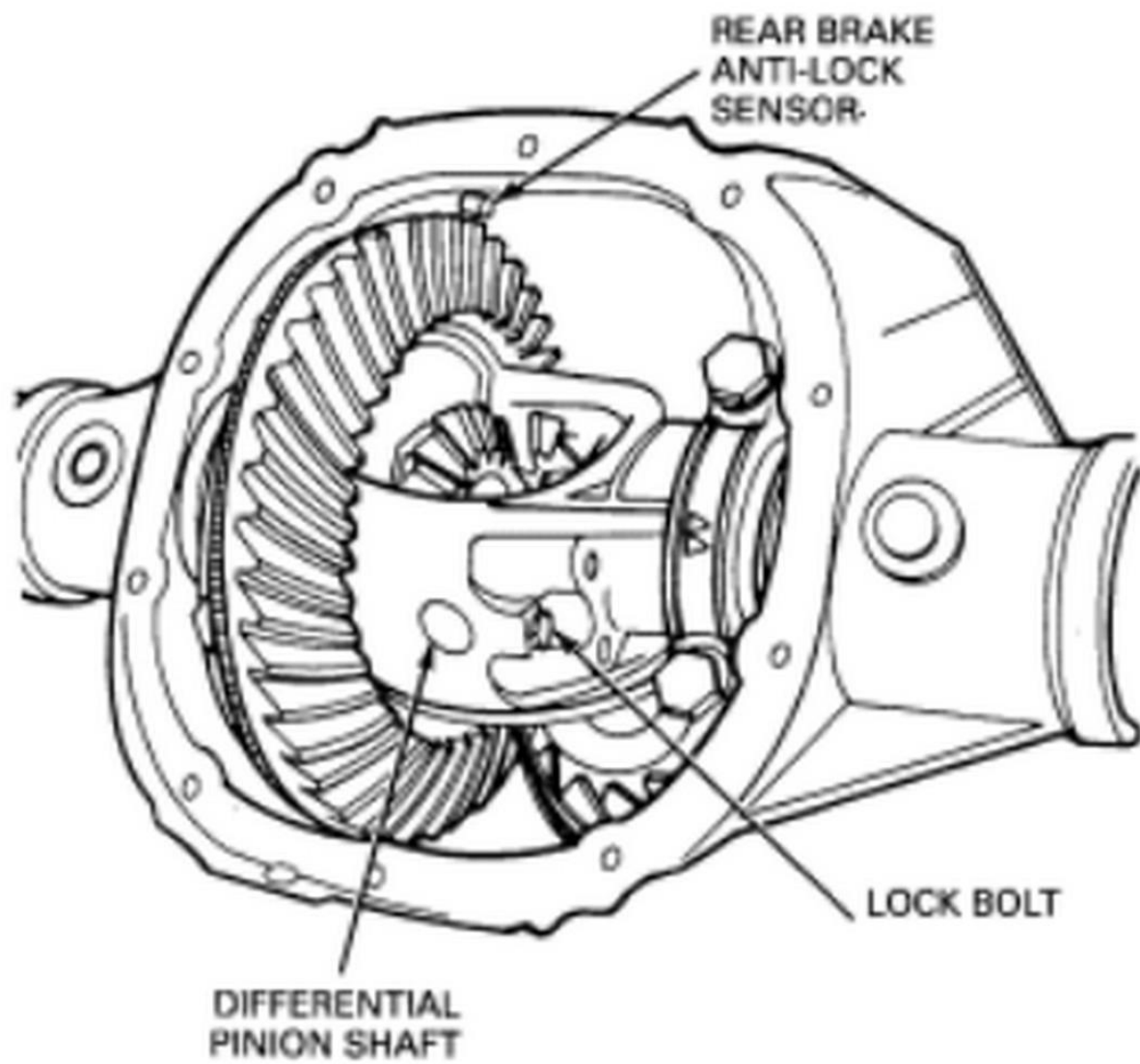
**Fig 1.4:** Variable geometry transmission: As the Idler moves from right to left it changes the angle of the call axle changing the transmission between the ball input and output discs.

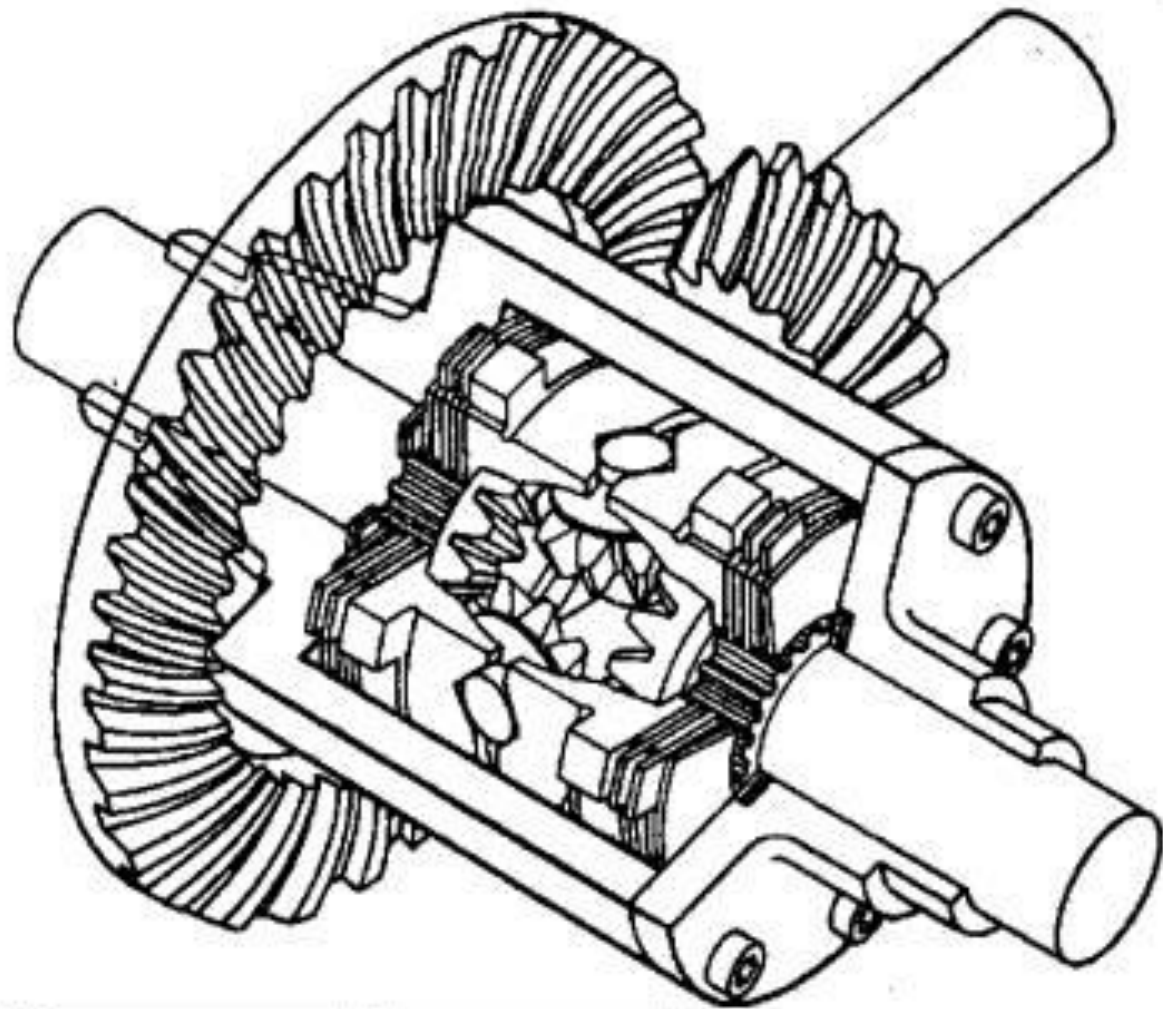


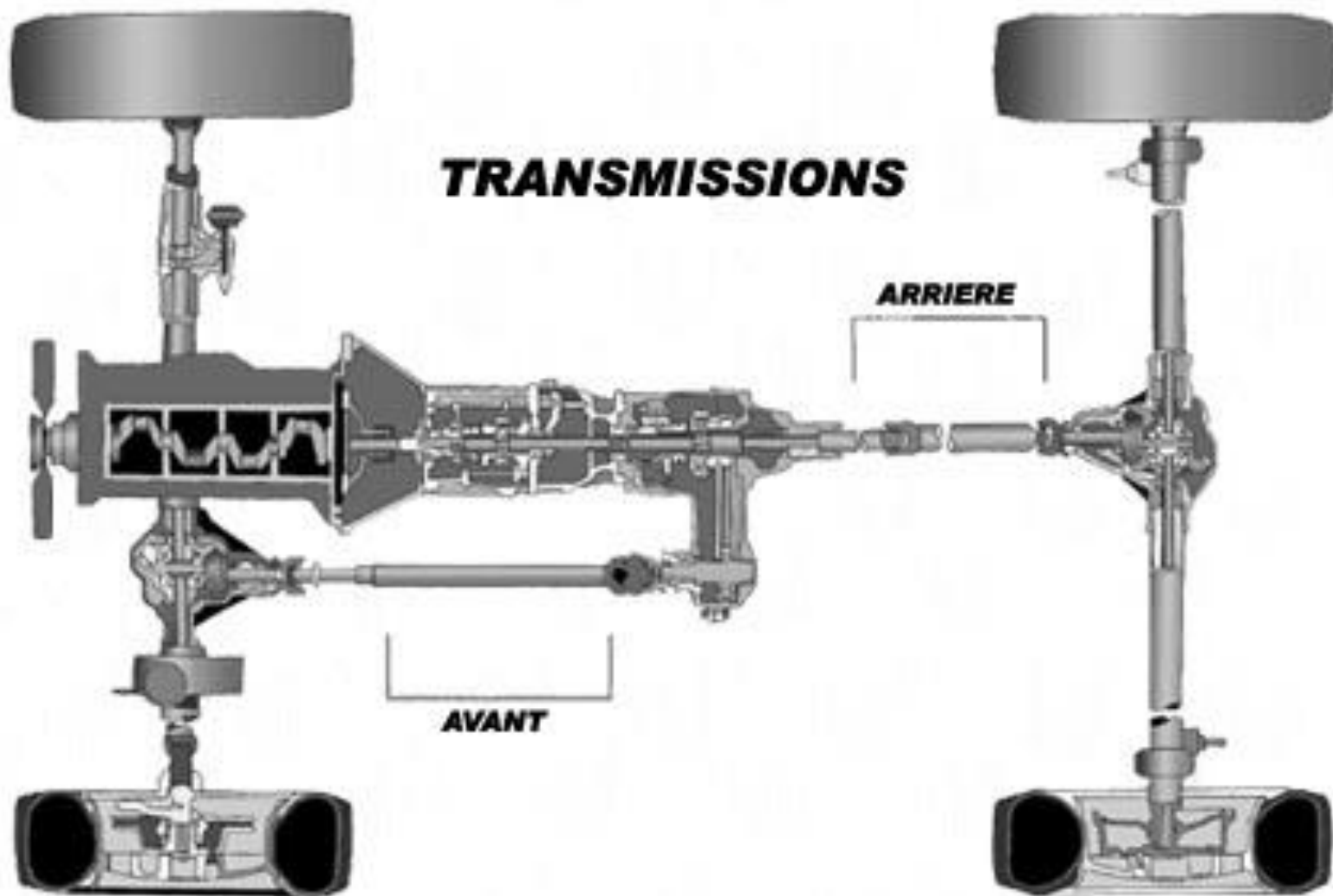


# CONVENTIONAL DIFFERENTIAL





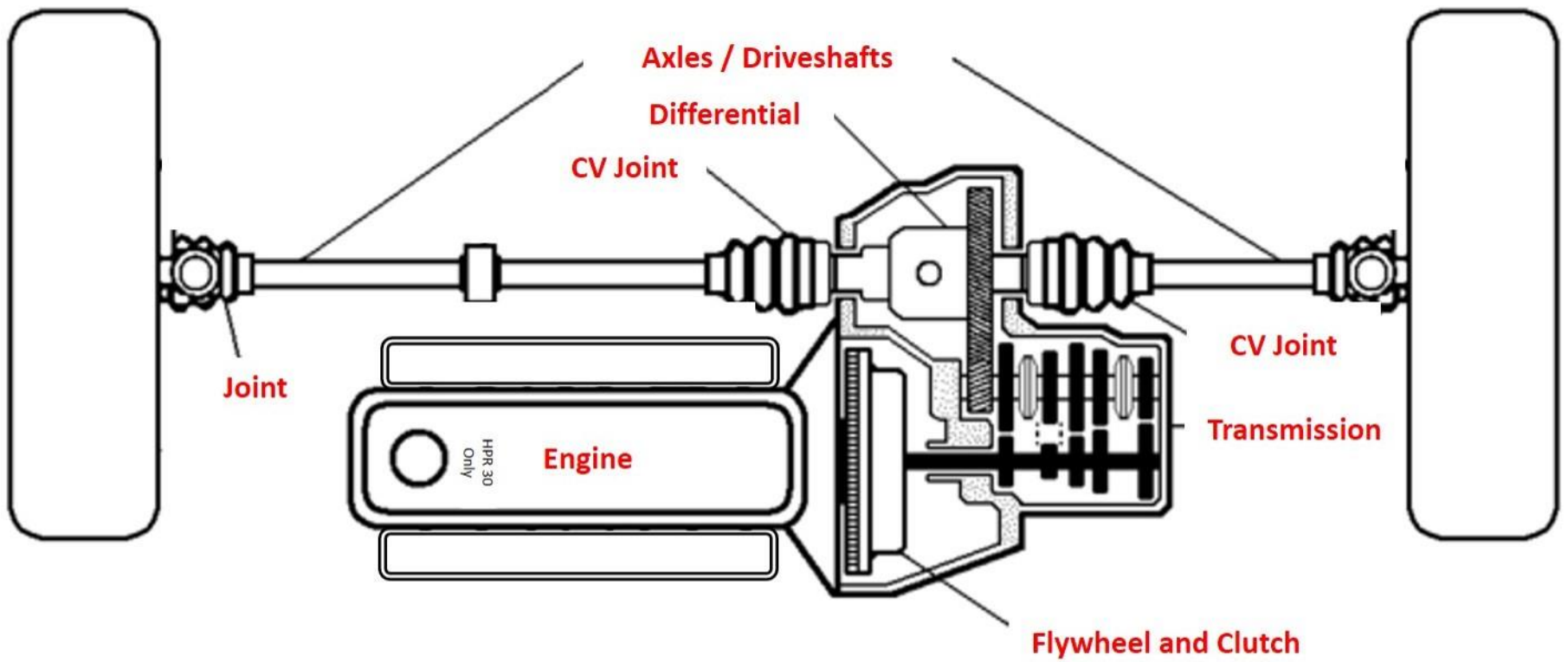


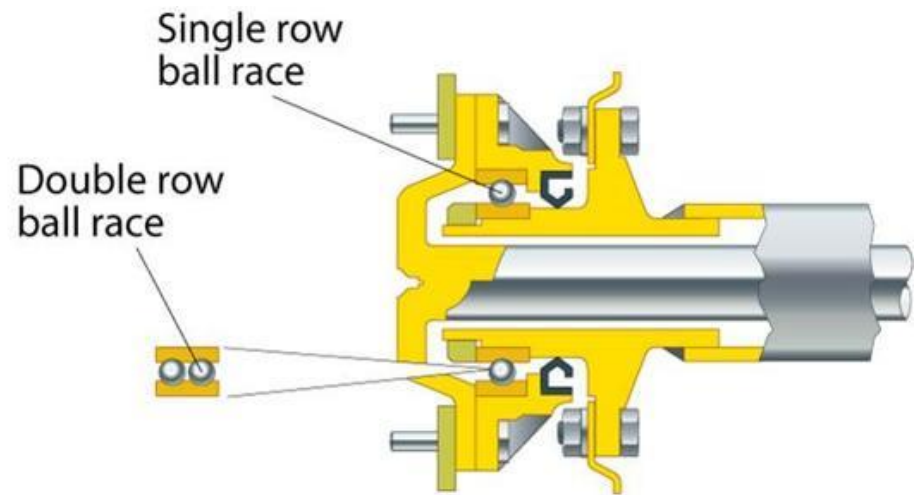
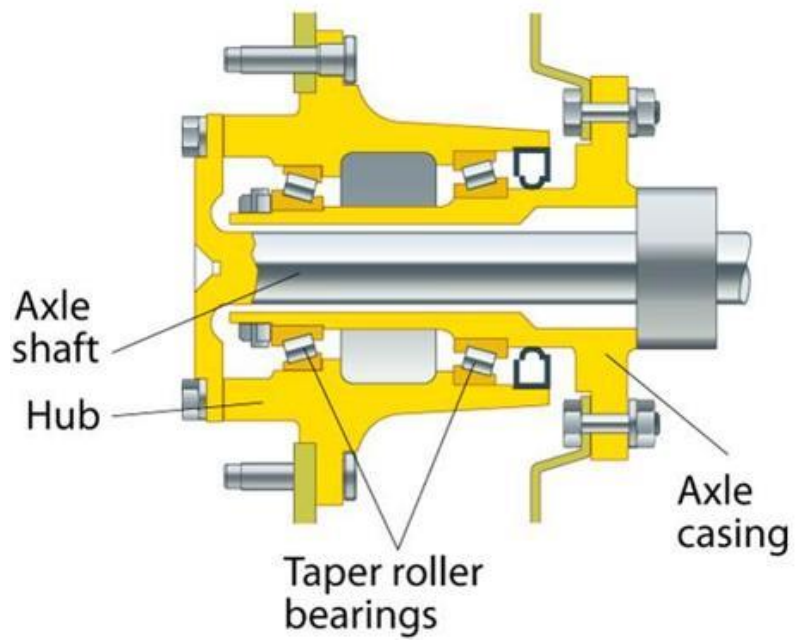


**TRANSMISSIONS**

**ARRIERE**

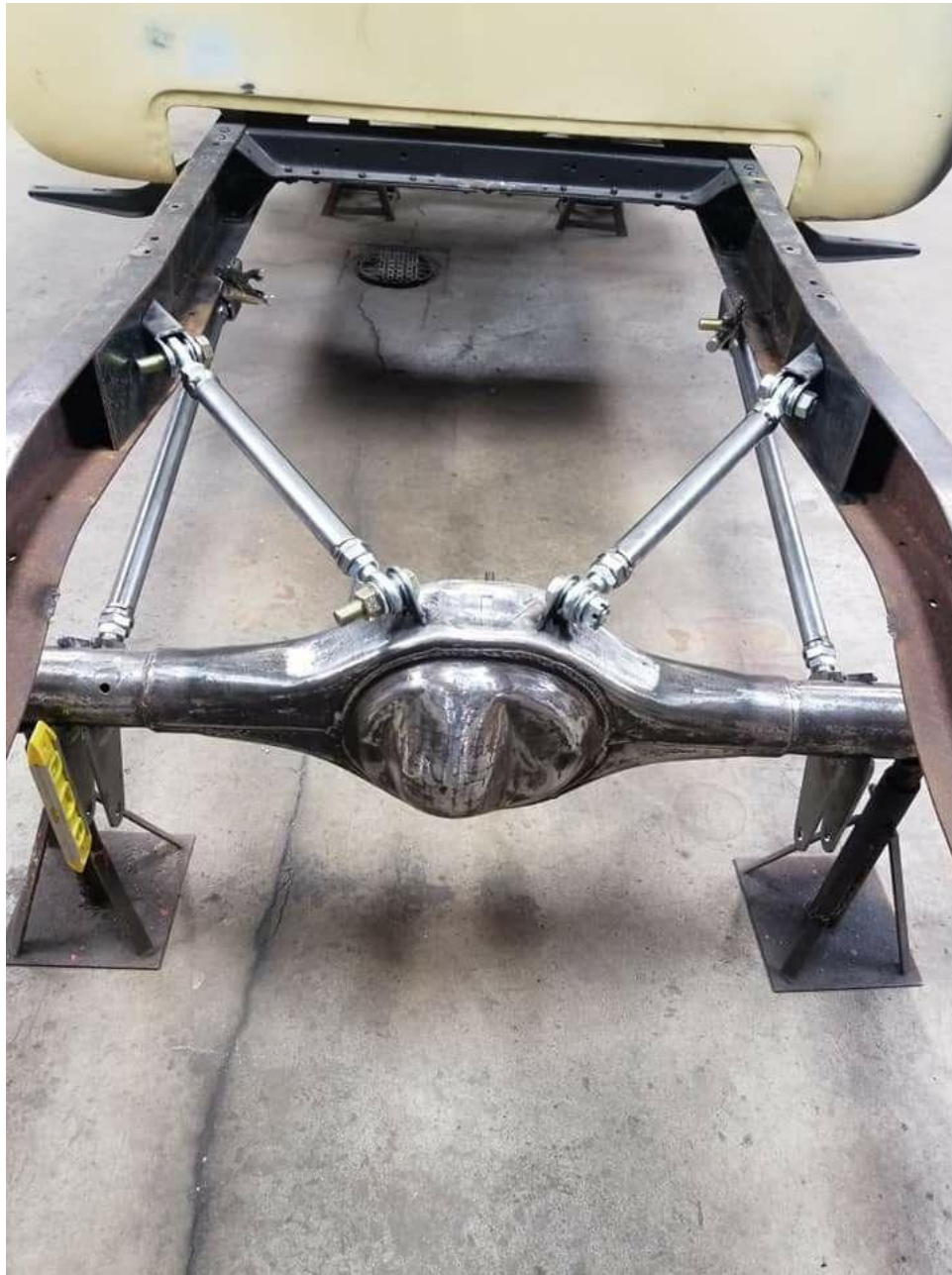
**AVANT**

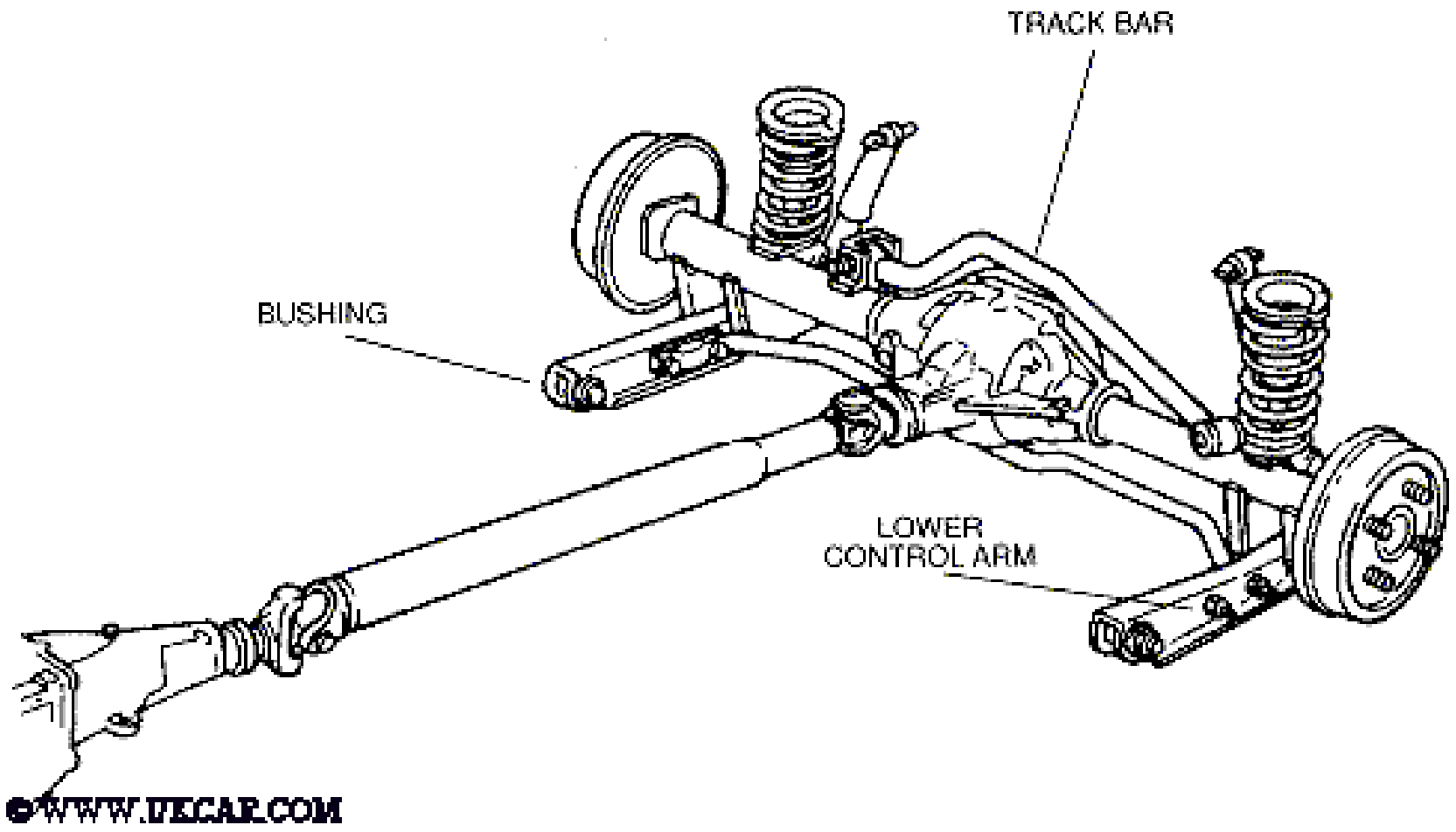


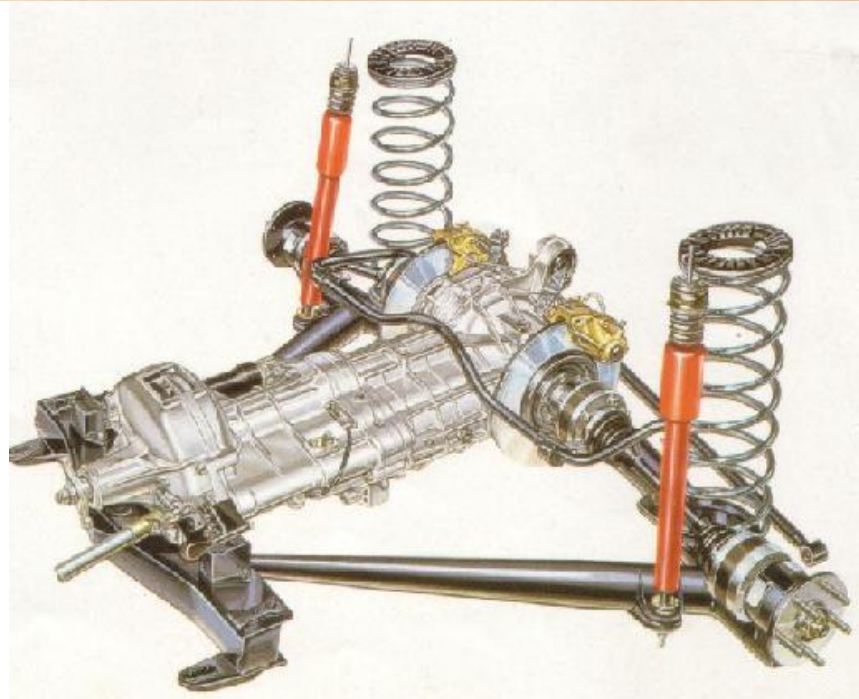
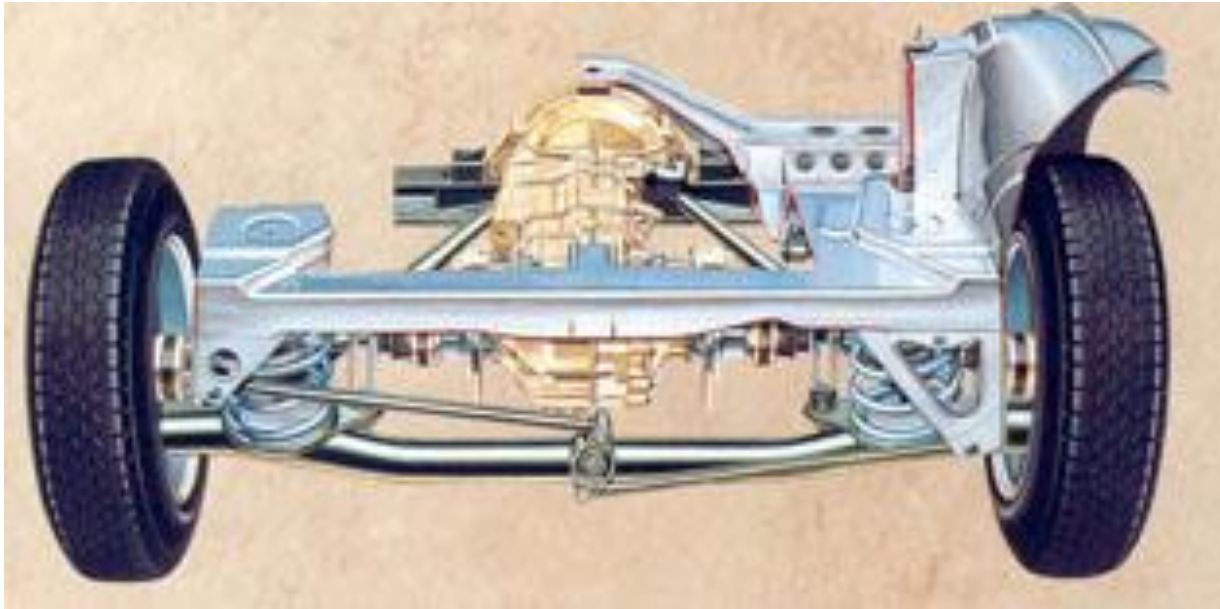












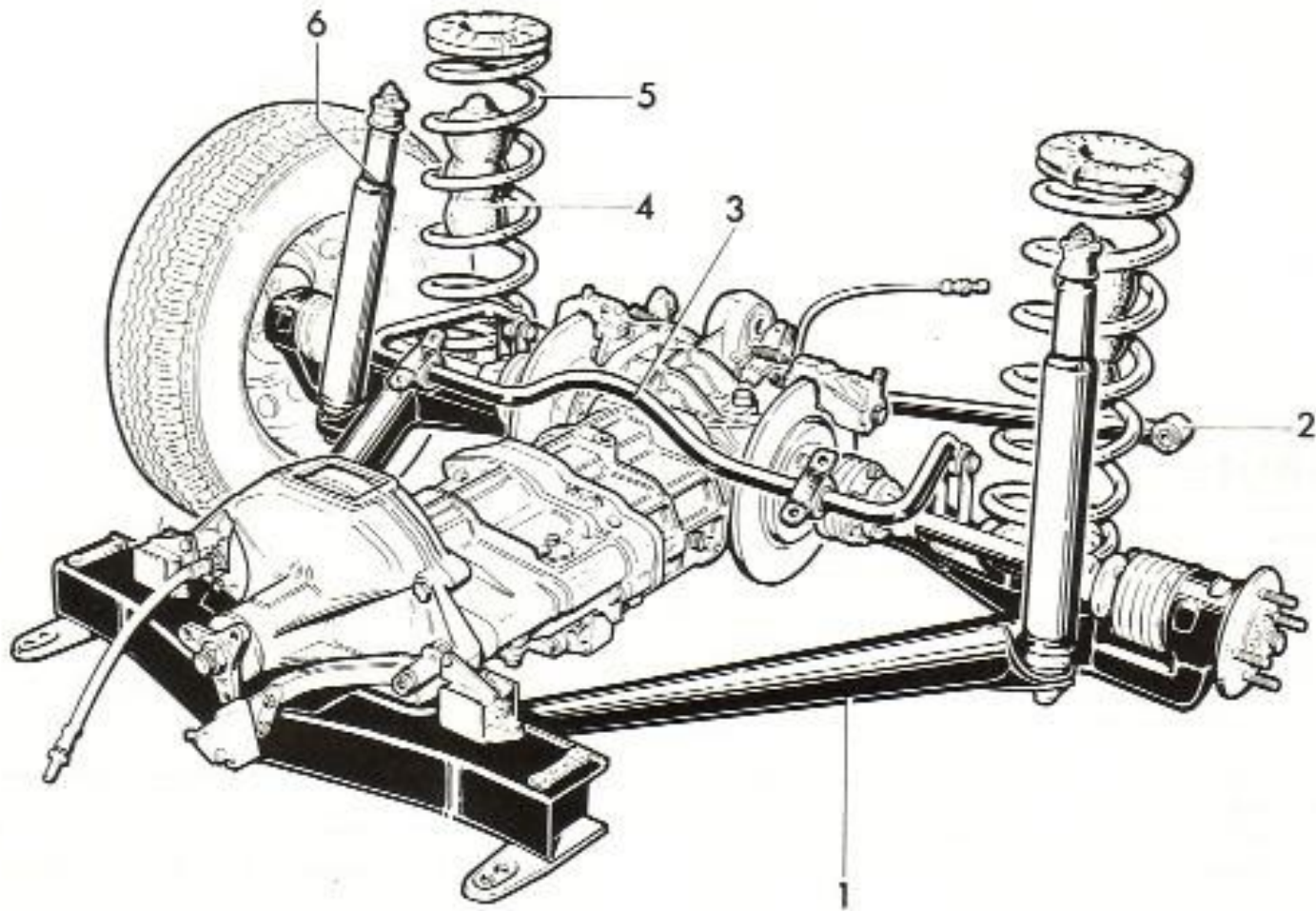
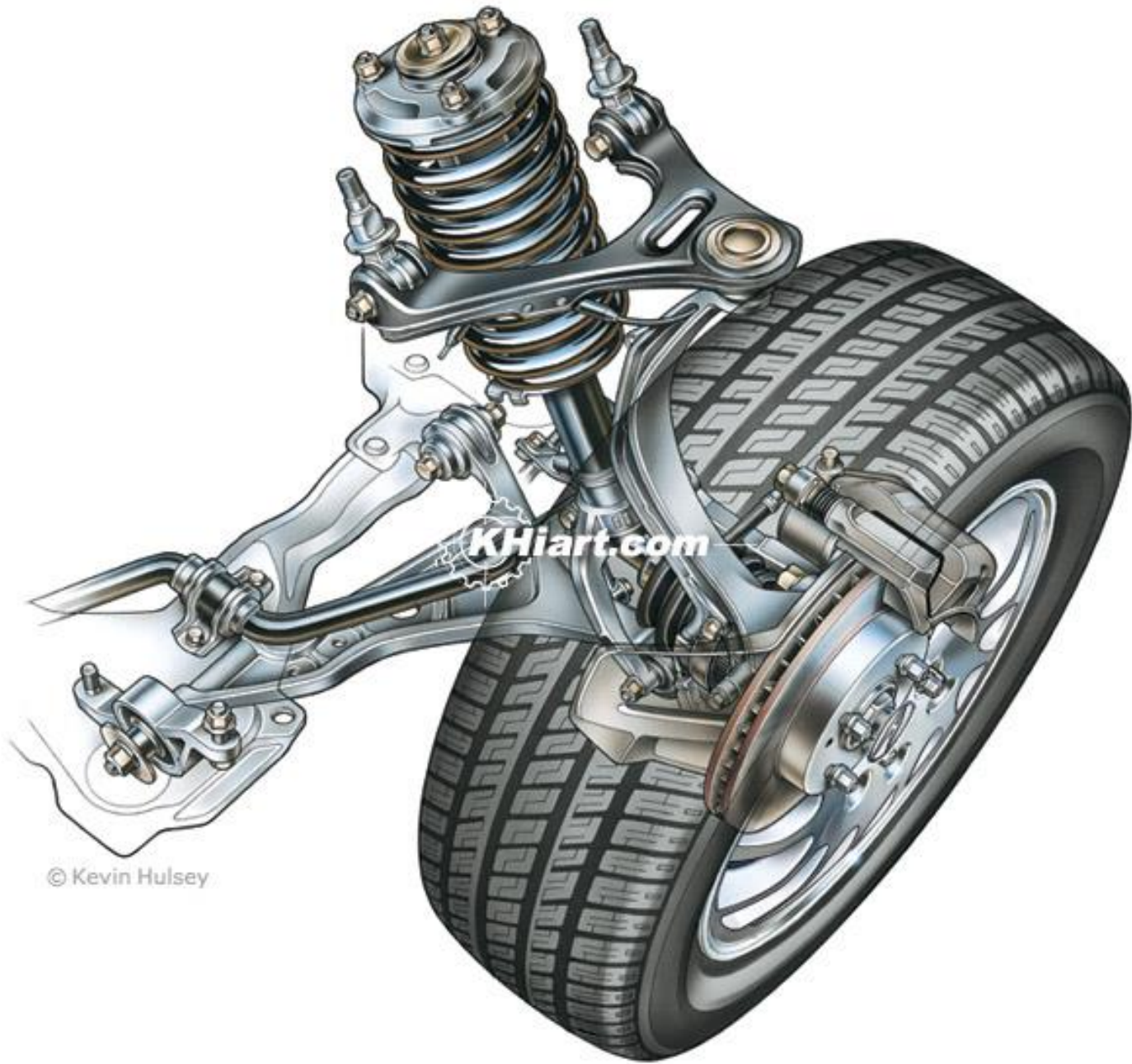


Fig. 11.1 Rear suspension components (Sec 1)

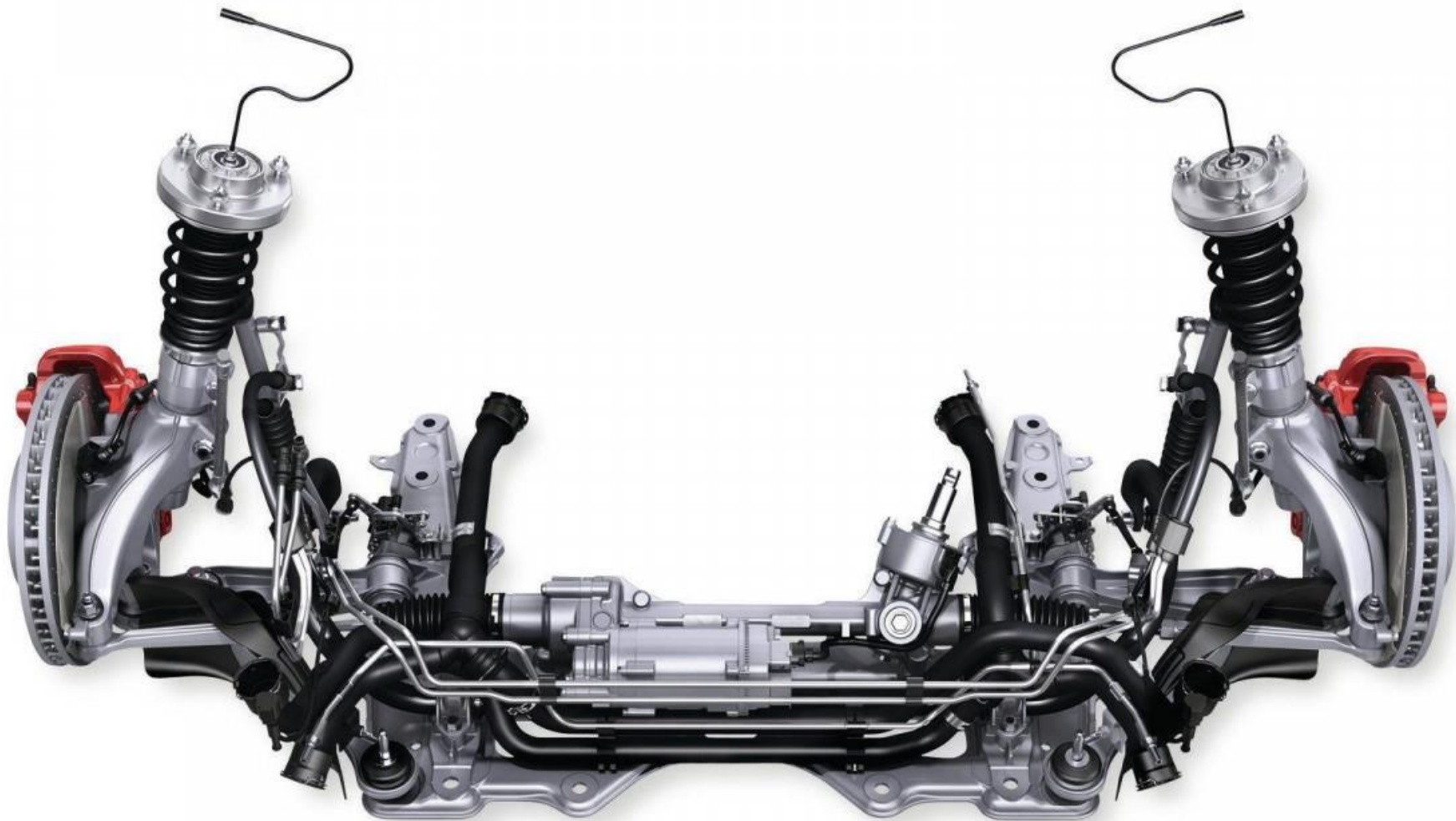
- |   |                 |   |               |   |                |
|---|-----------------|---|---------------|---|----------------|
| 1 | Axis side tube  | 3 | Anti-roll bar | 5 | Coil spring    |
| 2 | Transverse link | 4 | Bump rubber   | 6 | Shock absorber |



2009 Dodge Ram rear suspension  
Rob Martini for allpar.com



© Kevin Hulseley



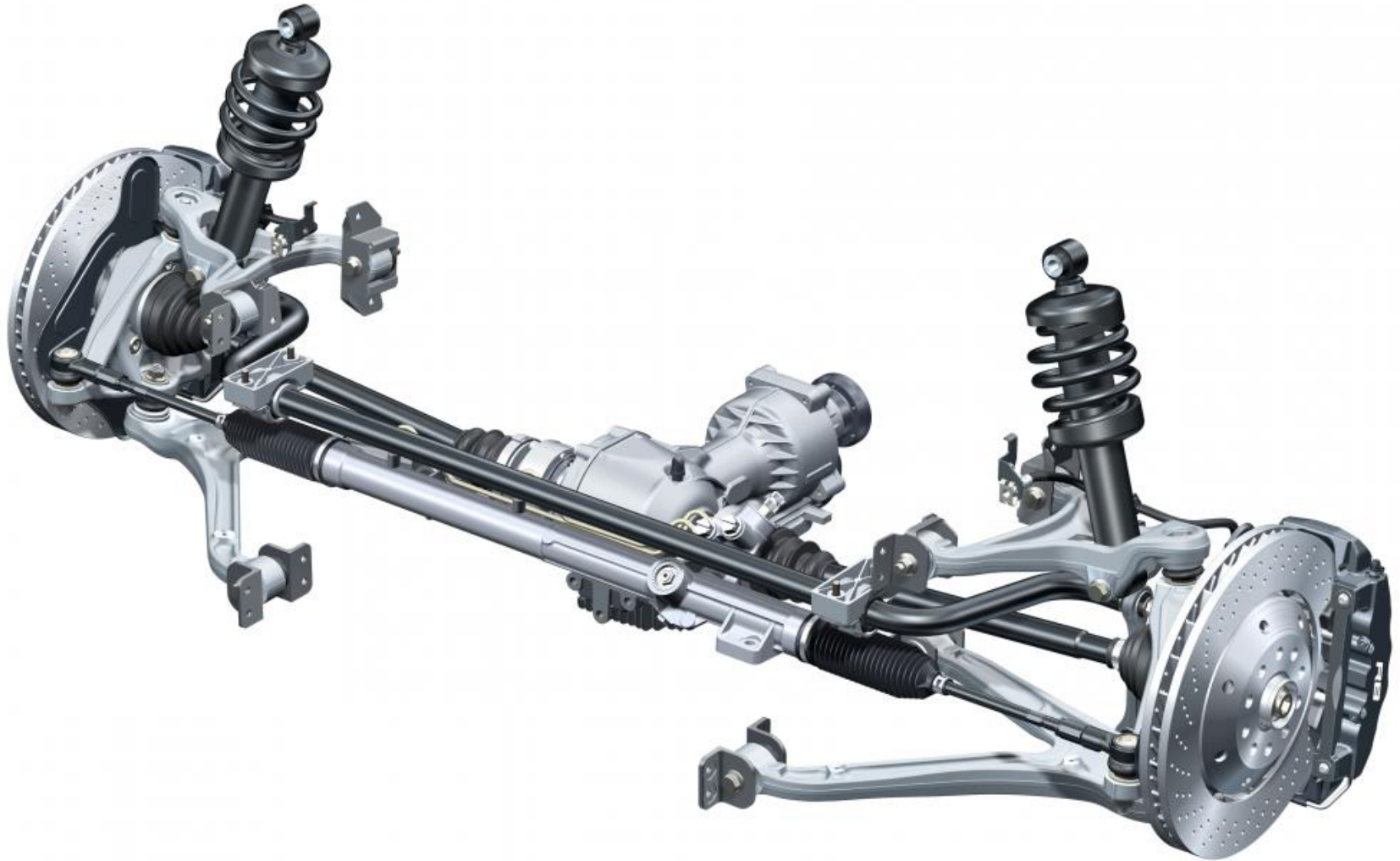
# Audi R8

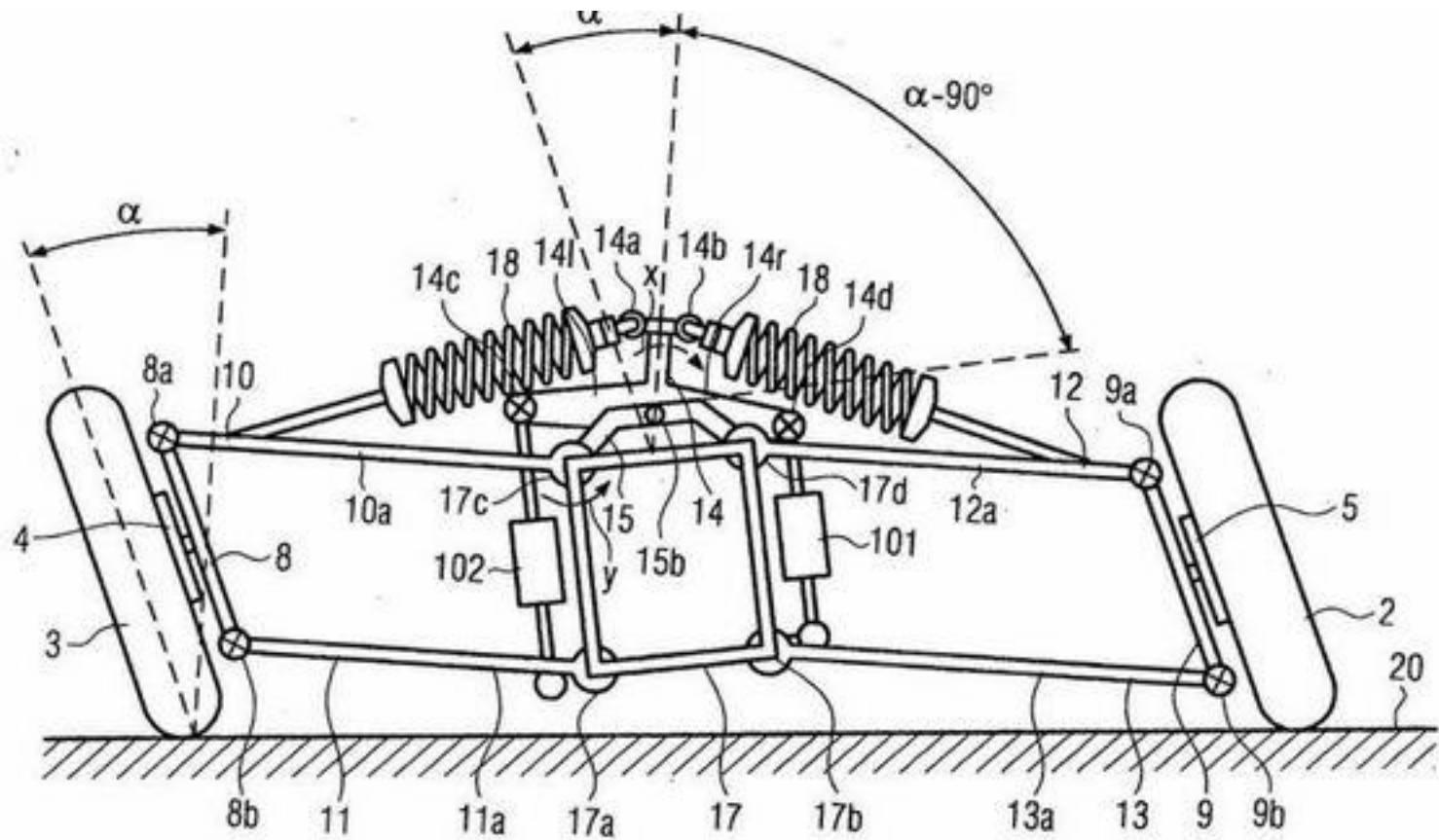
Doppelquerlenker Vorderachse mit Differenzial  
Double-wishbone front axle with differential

01/07



Audi







## Audi A1 Sportback

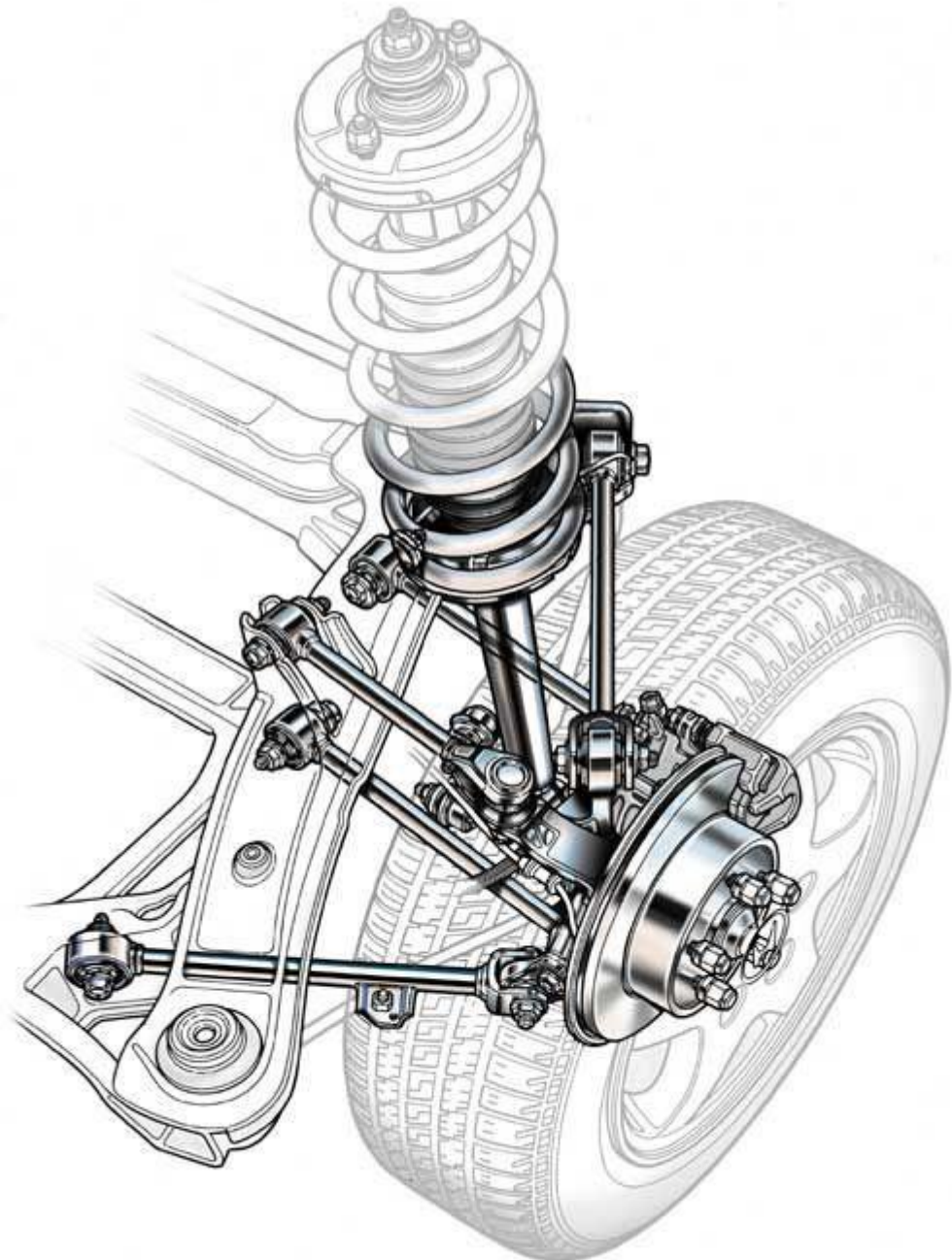
Verbundlenker-Hinterachse  
Torsion beam rear suspension

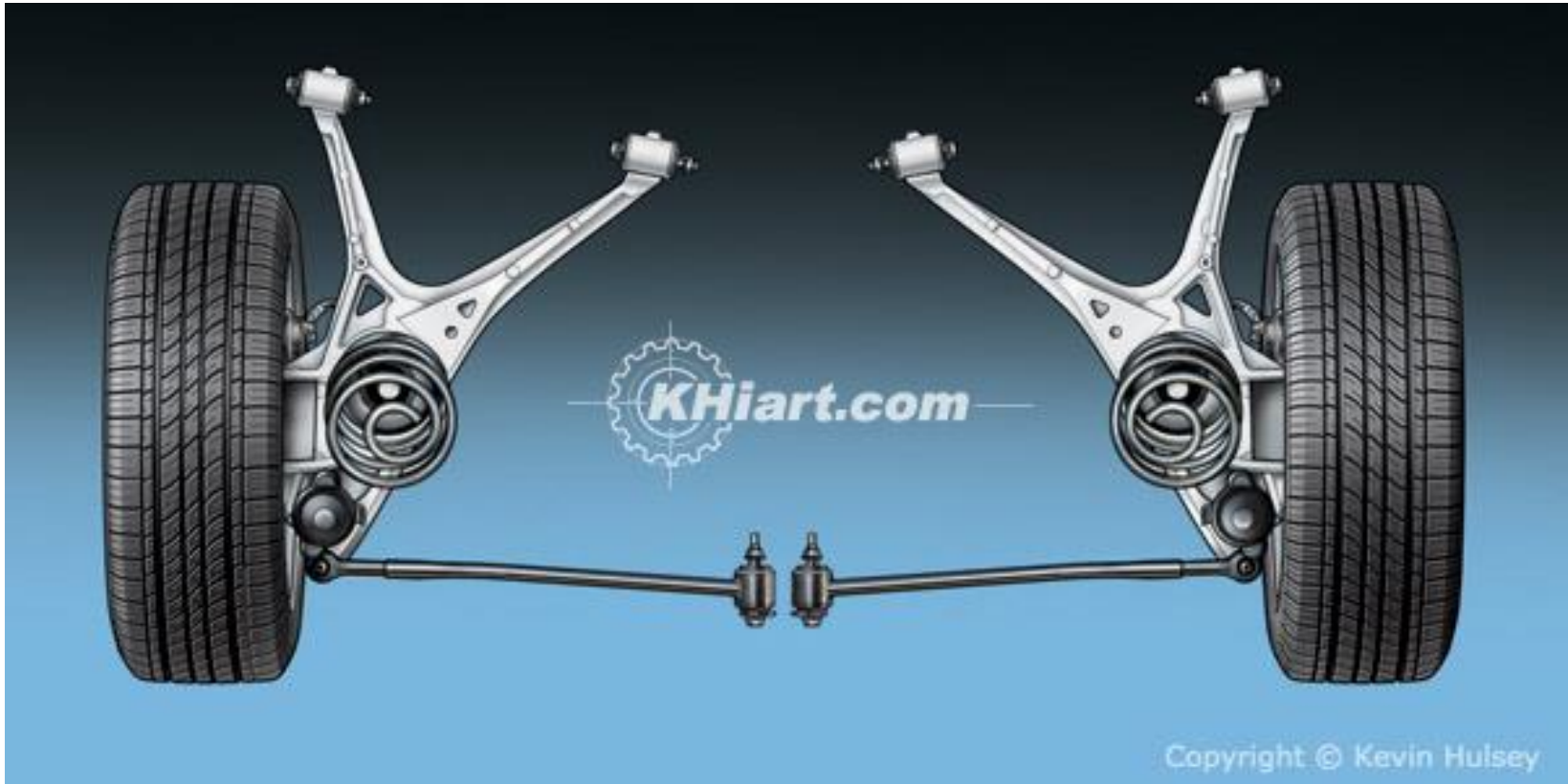
11/18

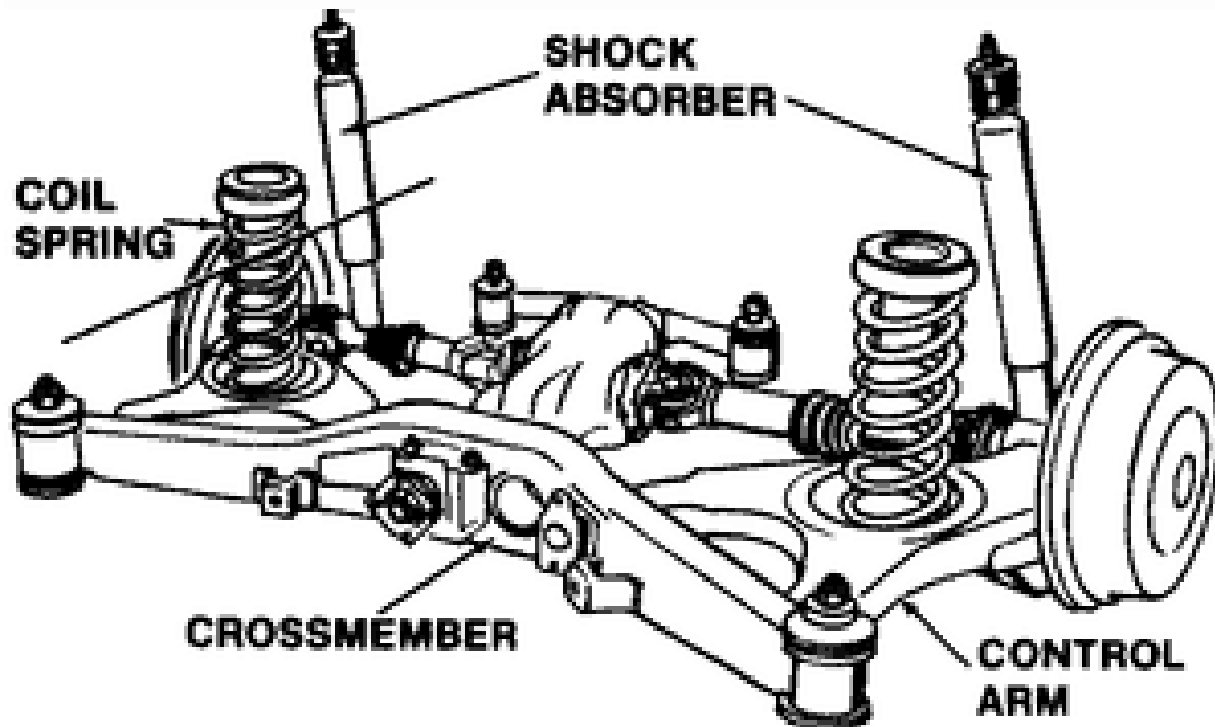


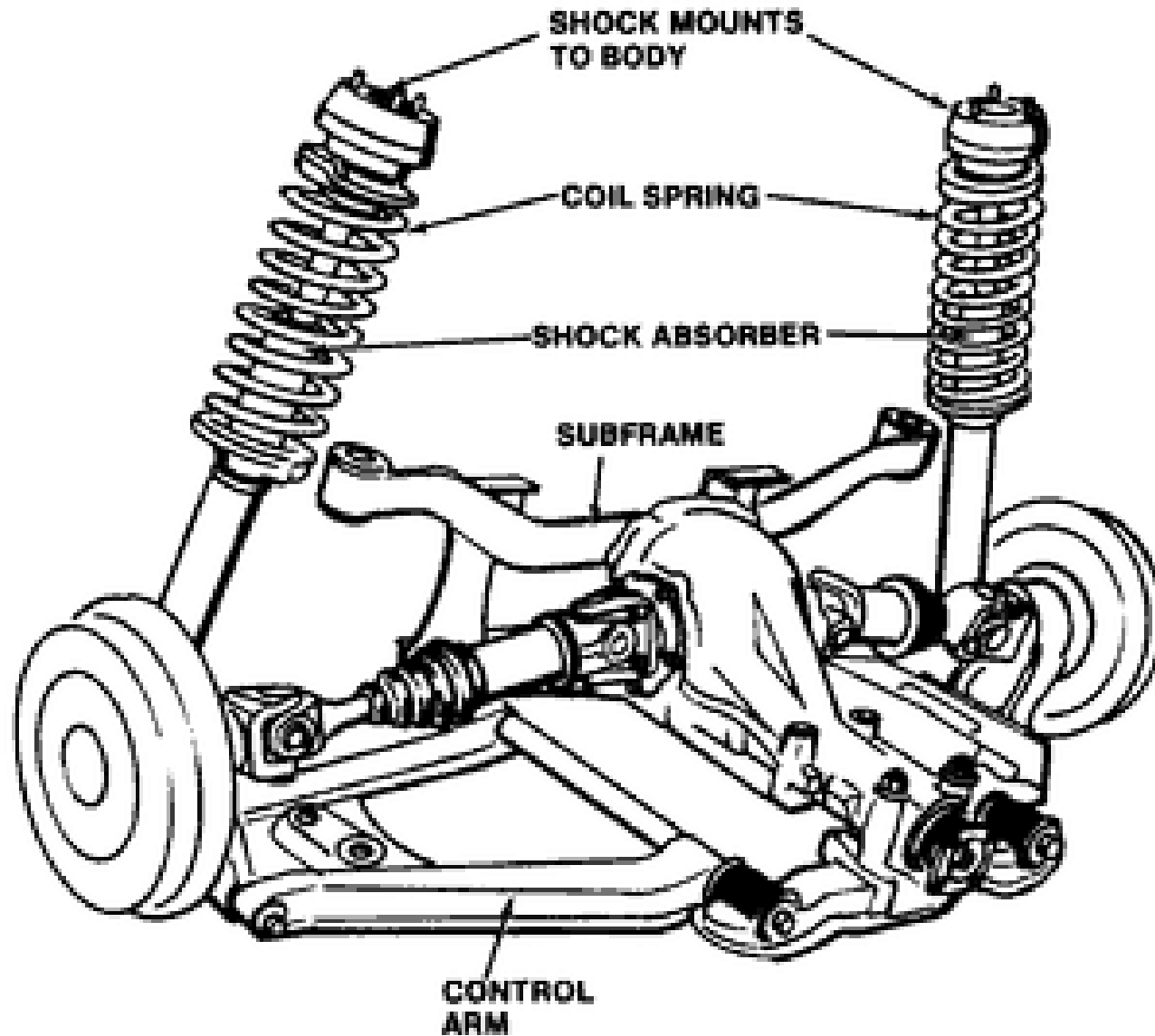














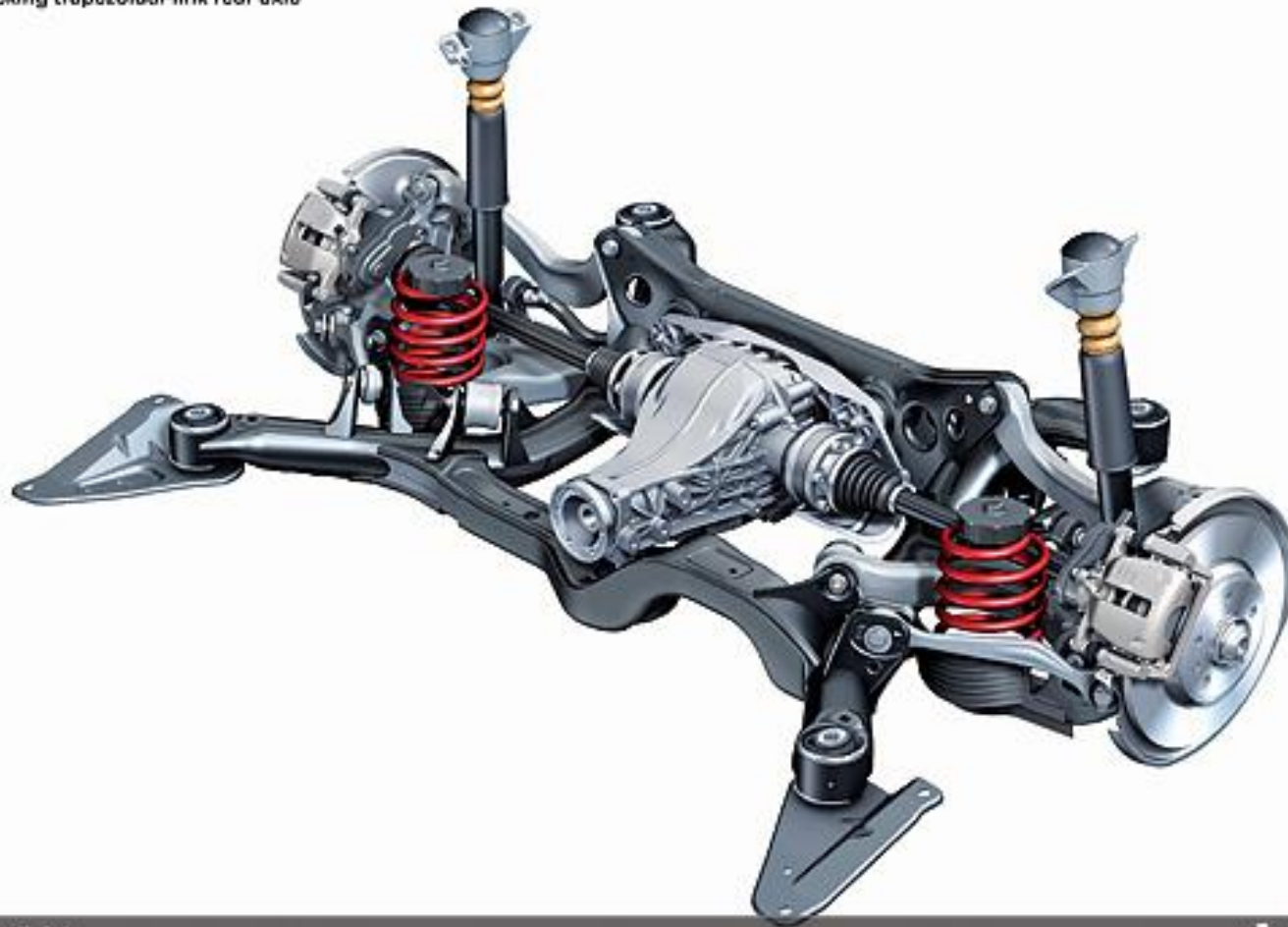


## Audi A4 quattro

### Spurgesteuerte Trapezlenker-Hinterachse

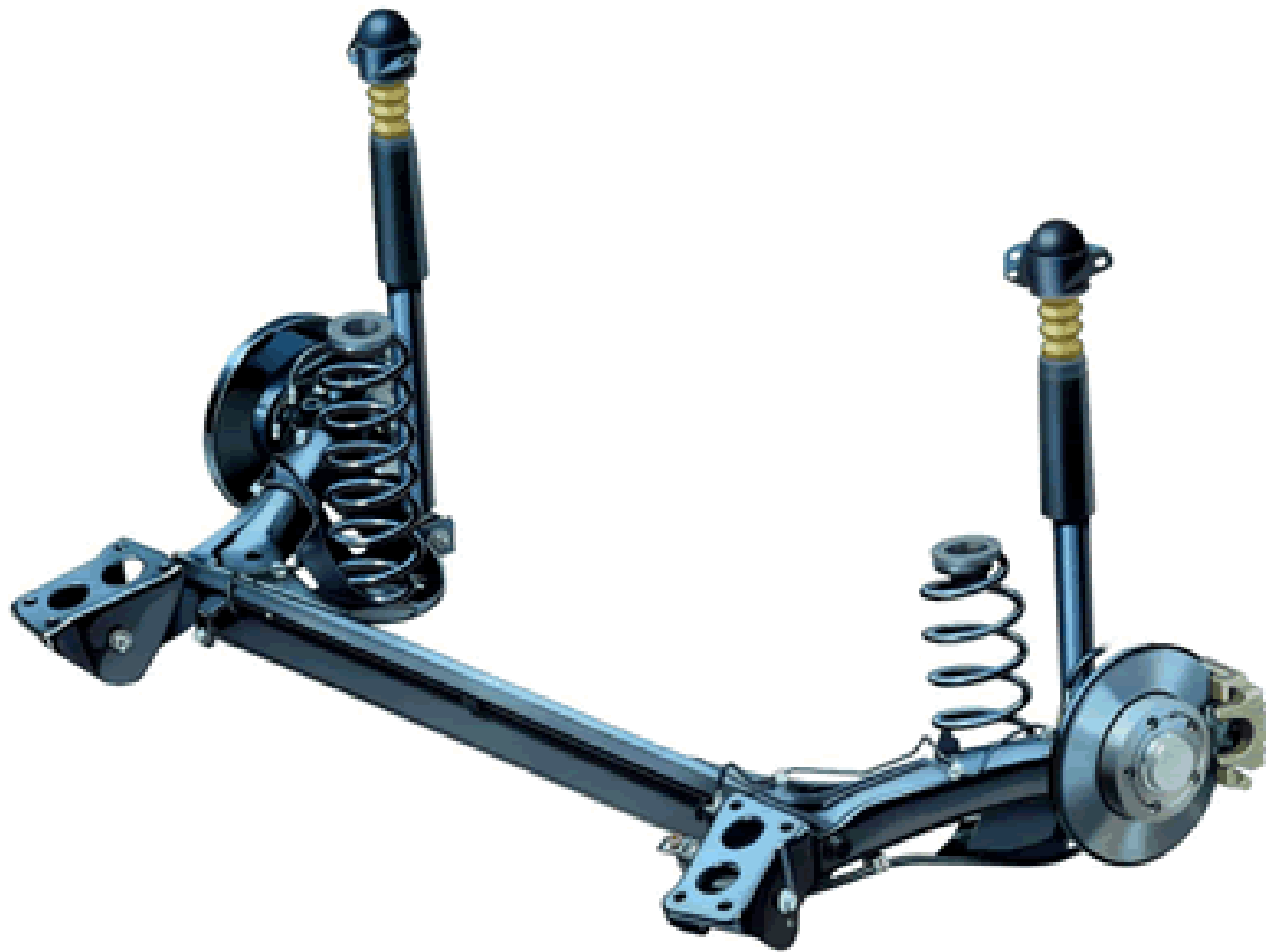
Self-tracking trapezoidal-link rear axle

10/07

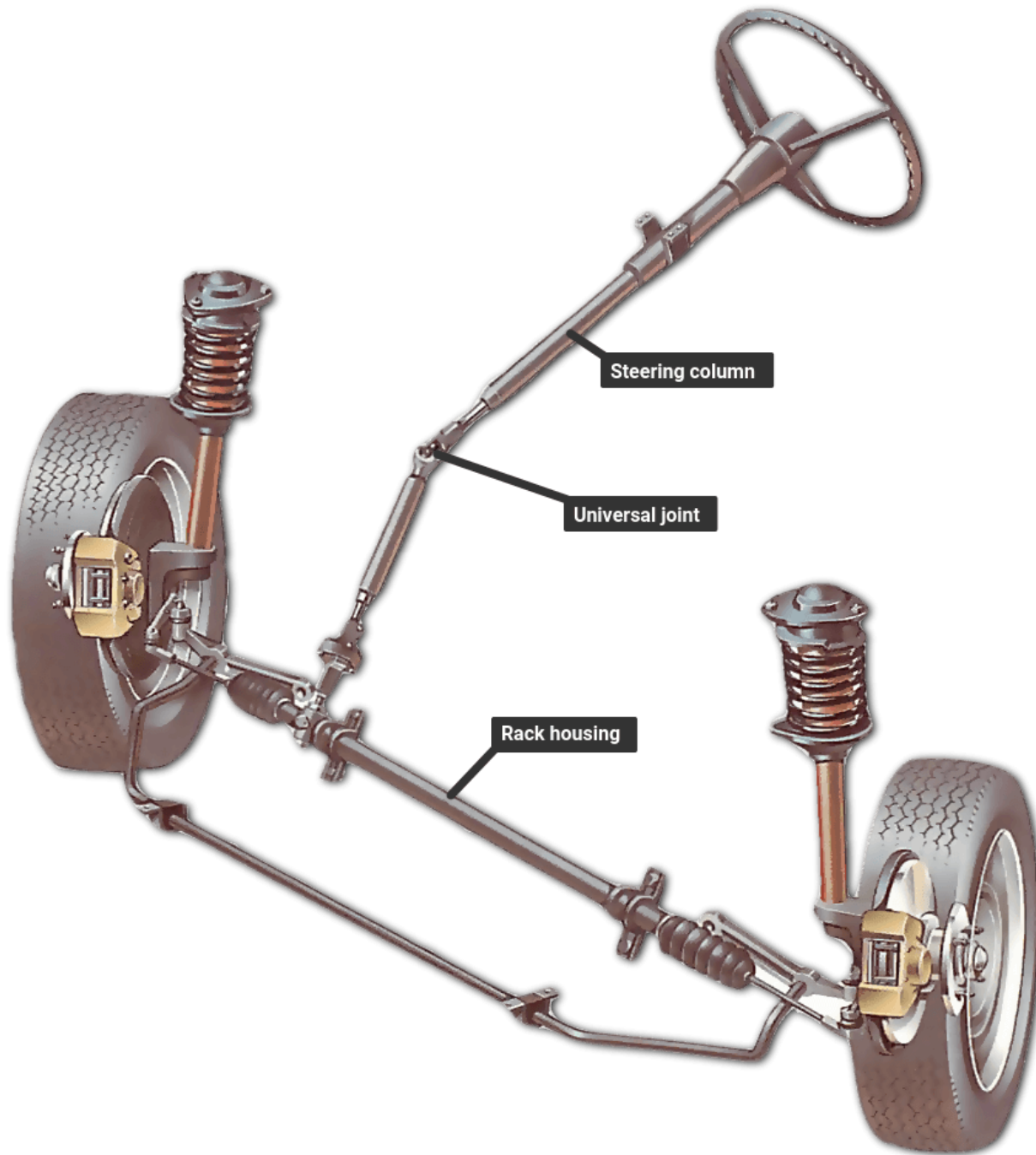


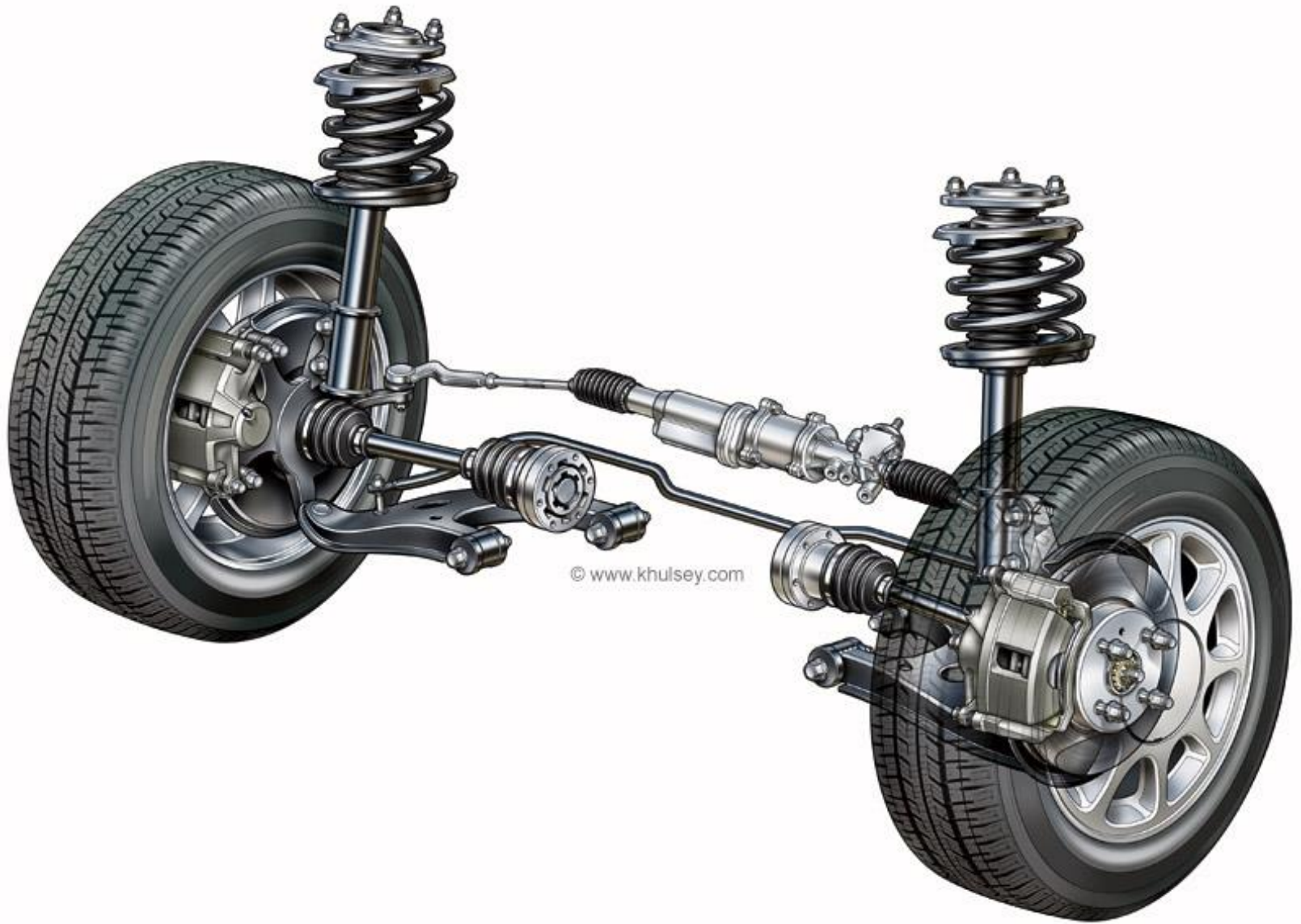
The B8 Audi A4

AudiWorld

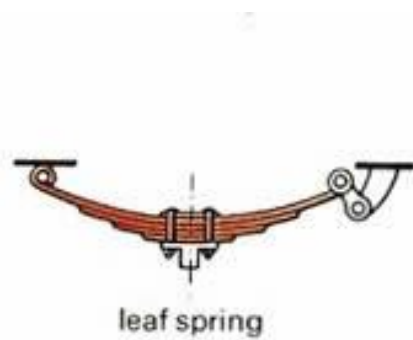












leaf spring



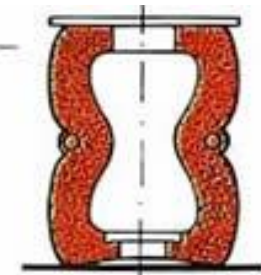
cylindrical helix



conical helix



torsion bar



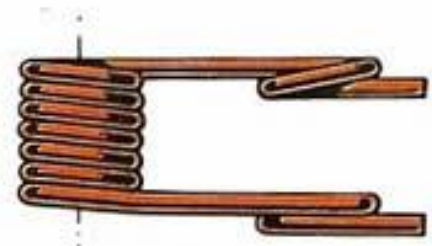
rubber



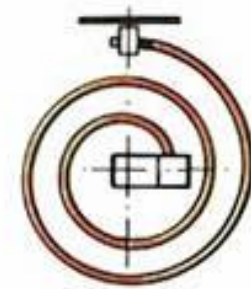
disc spring



tension spring



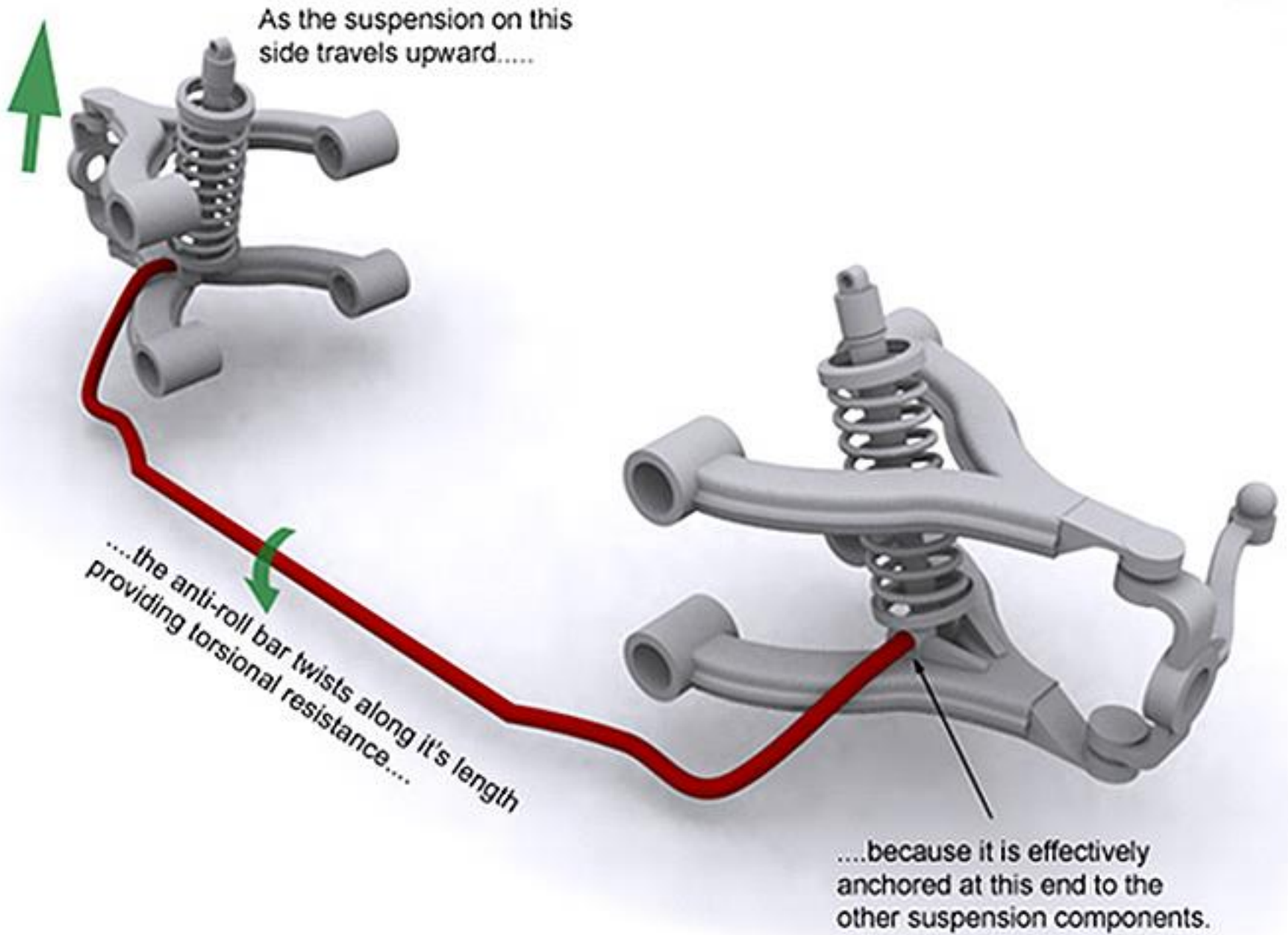
turn spring



spiral spring



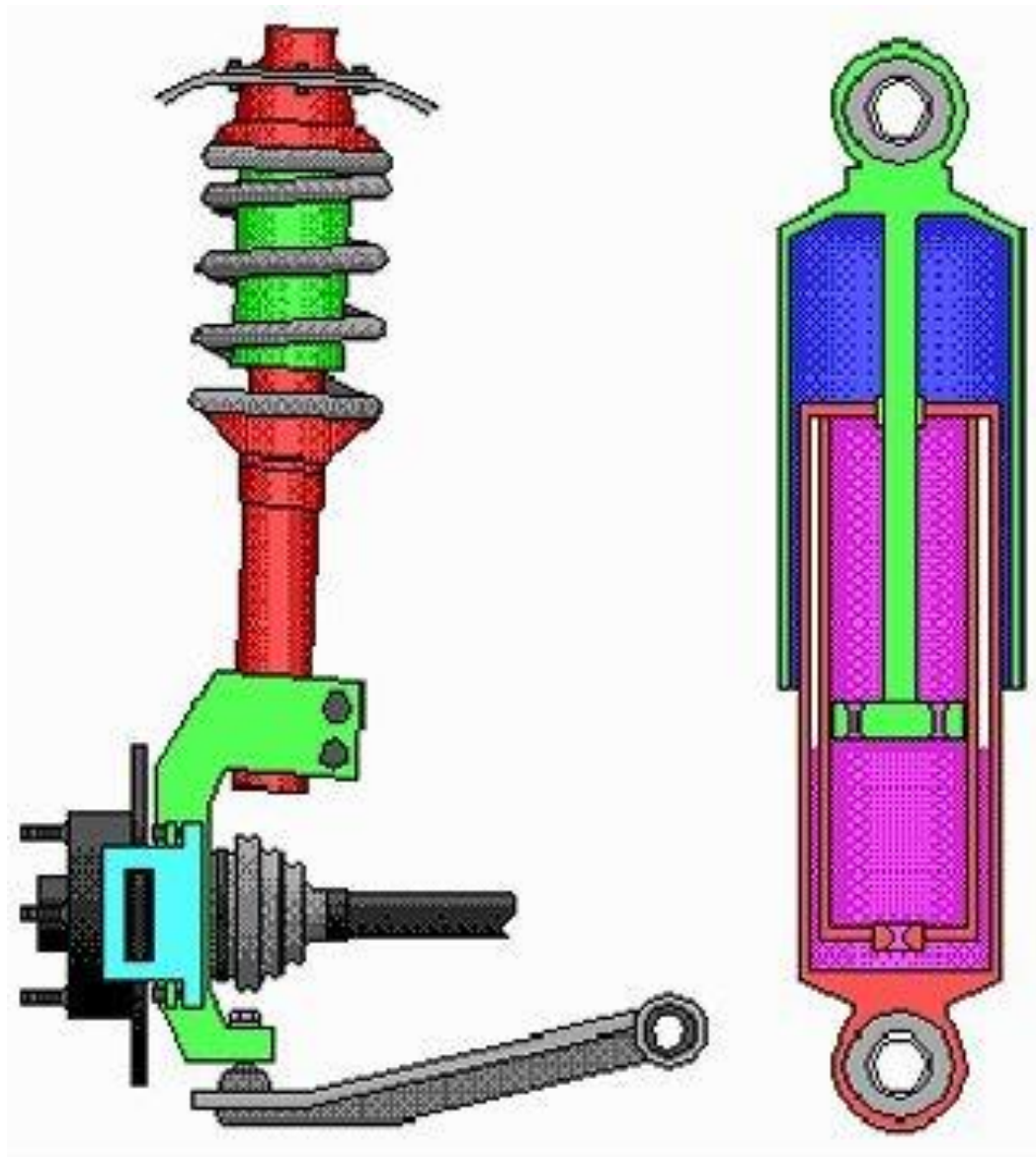
tape spring



As the suspension on this side travels upward.....

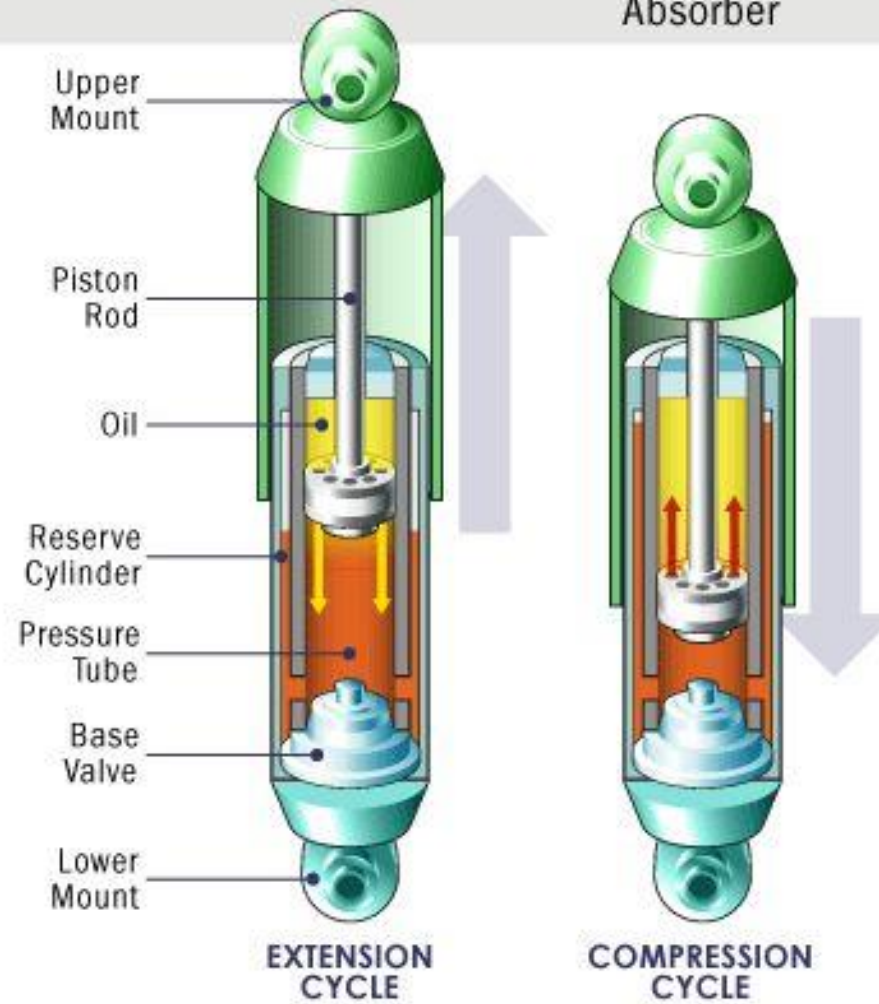
....the anti-roll bar twists along it's length providing torsional resistance....

...because it is effectively anchored at this end to the other suspension components.



## HOW CAR SUSPENSIONS WORK

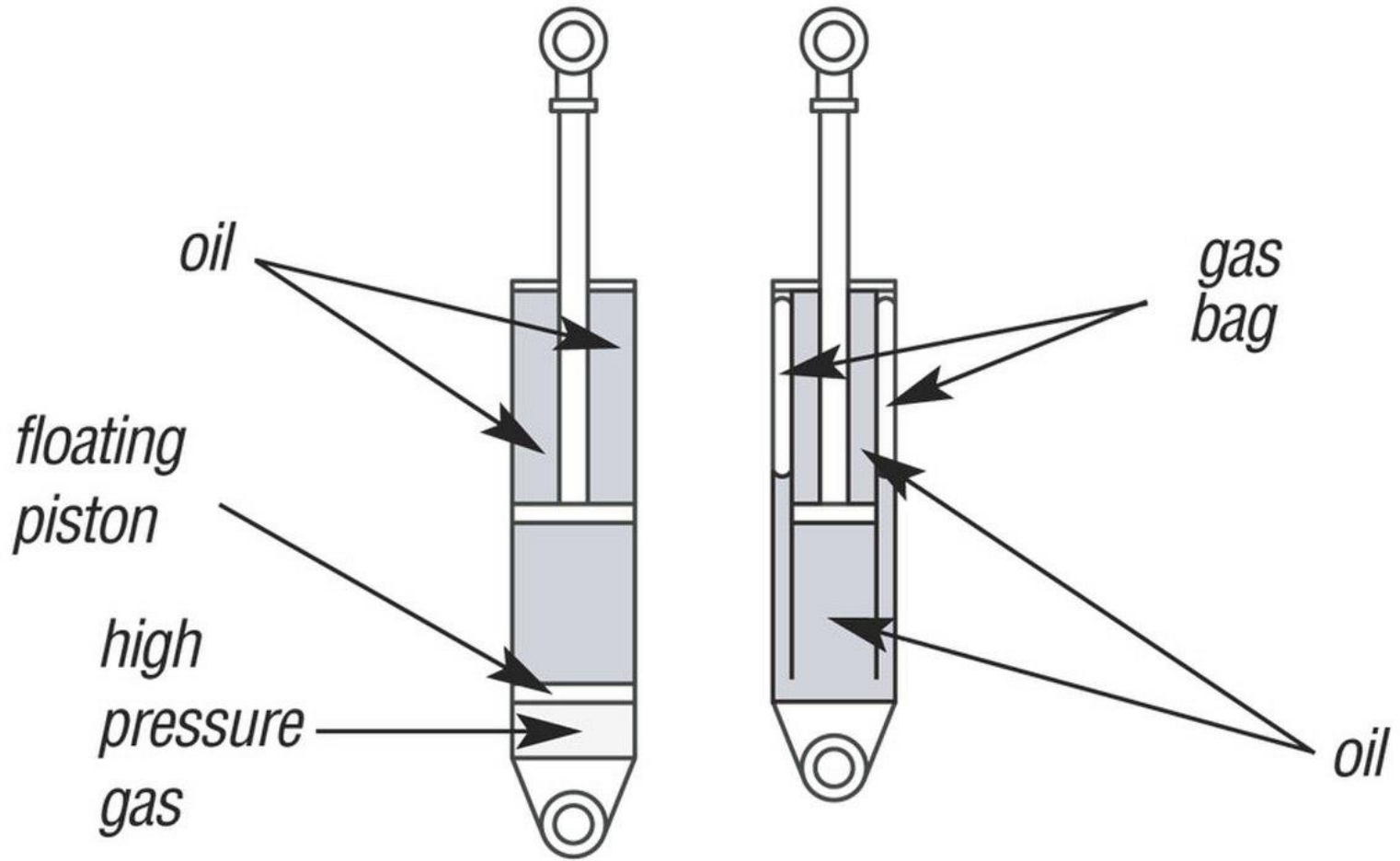
### Twin-tube Shock Absorber

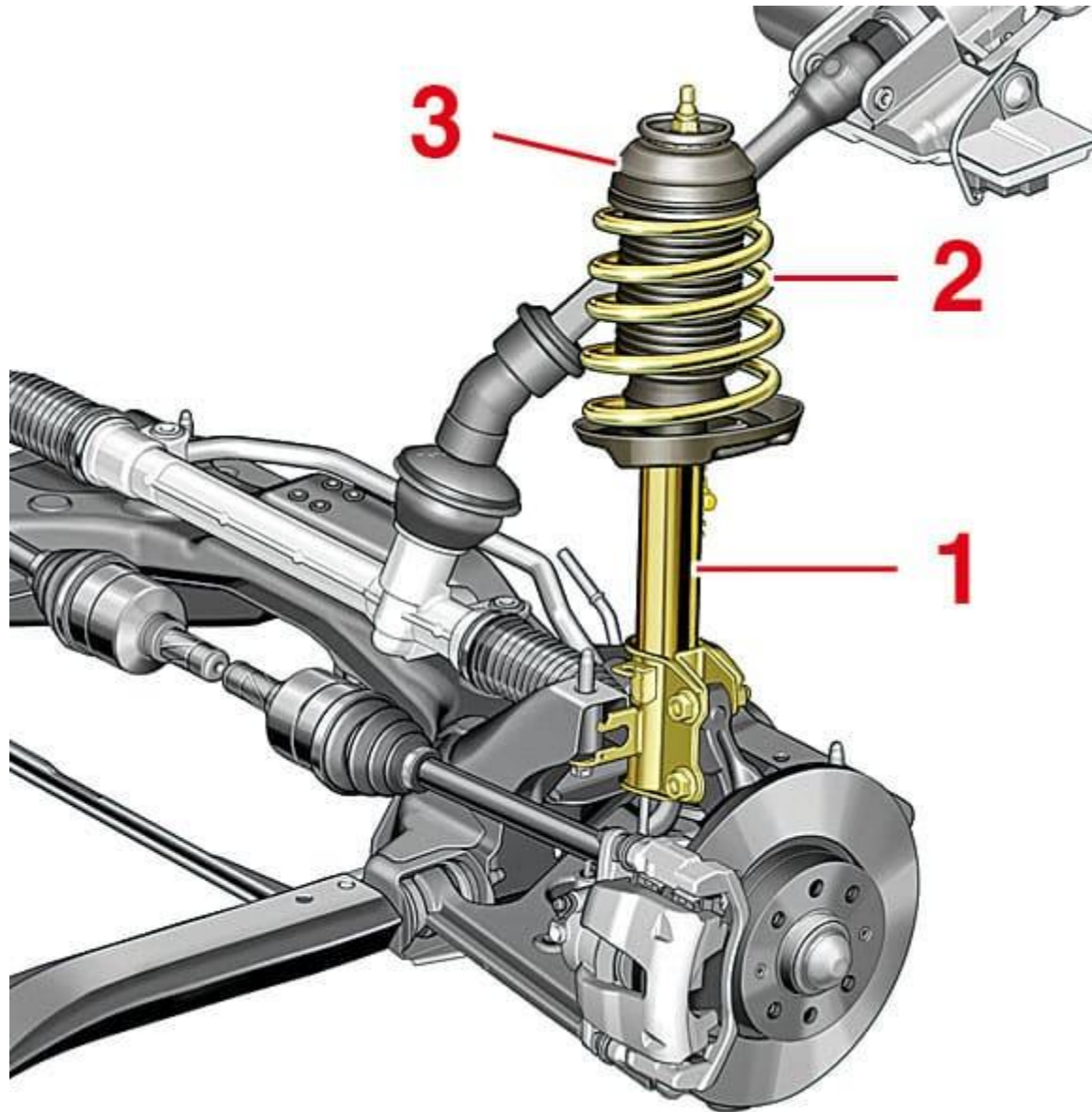


©2005 Howstuffworks

### Monotube

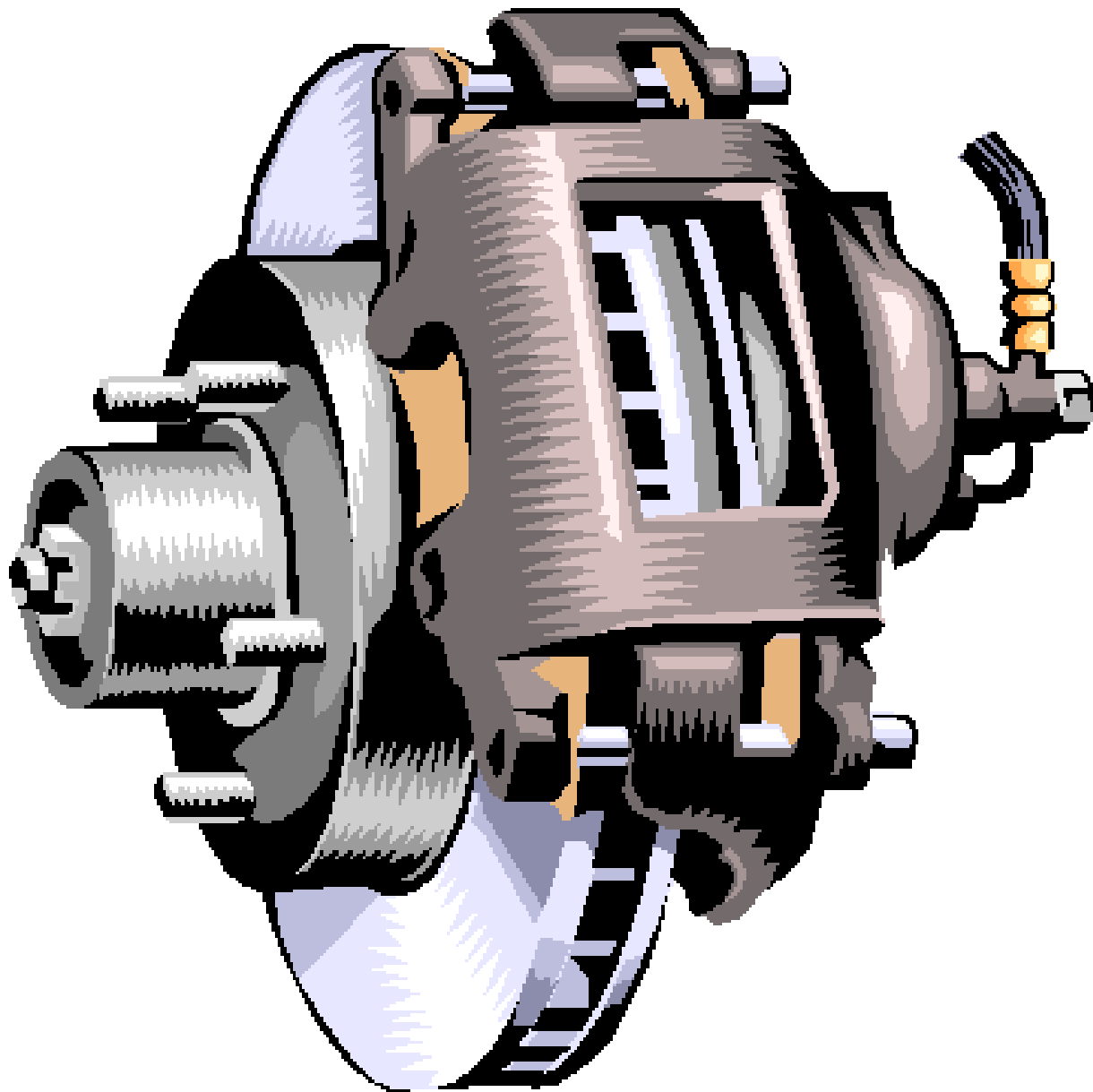
### Twin Tube

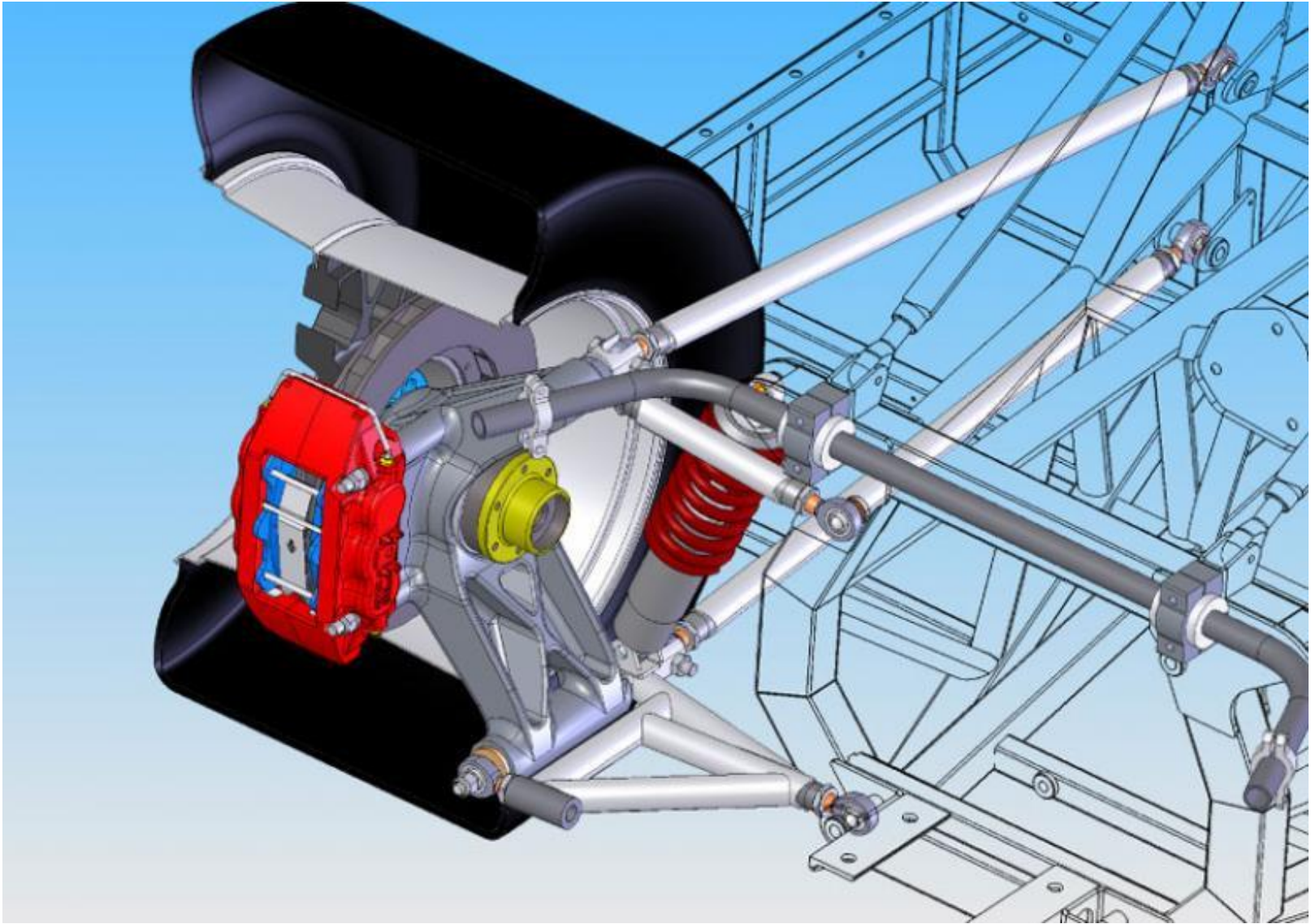




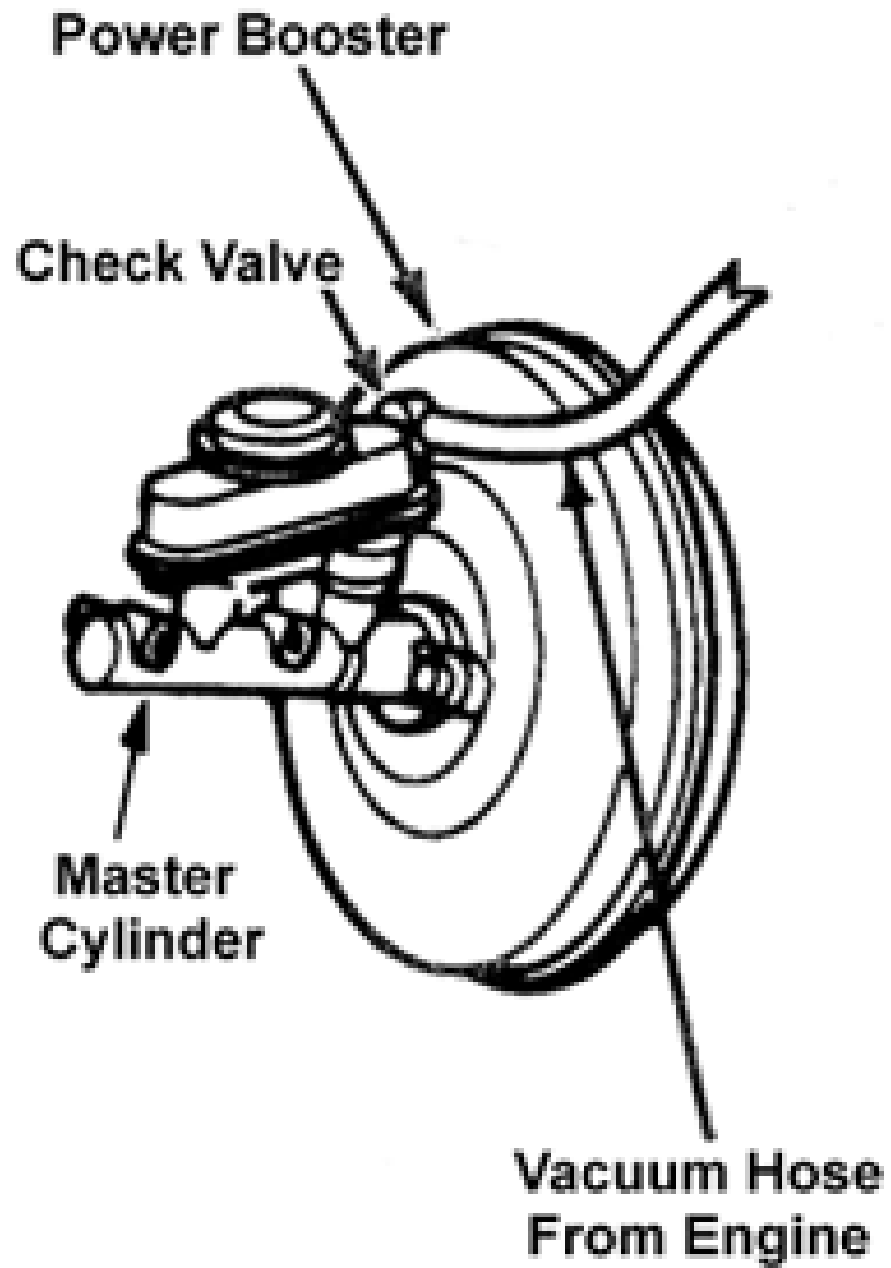


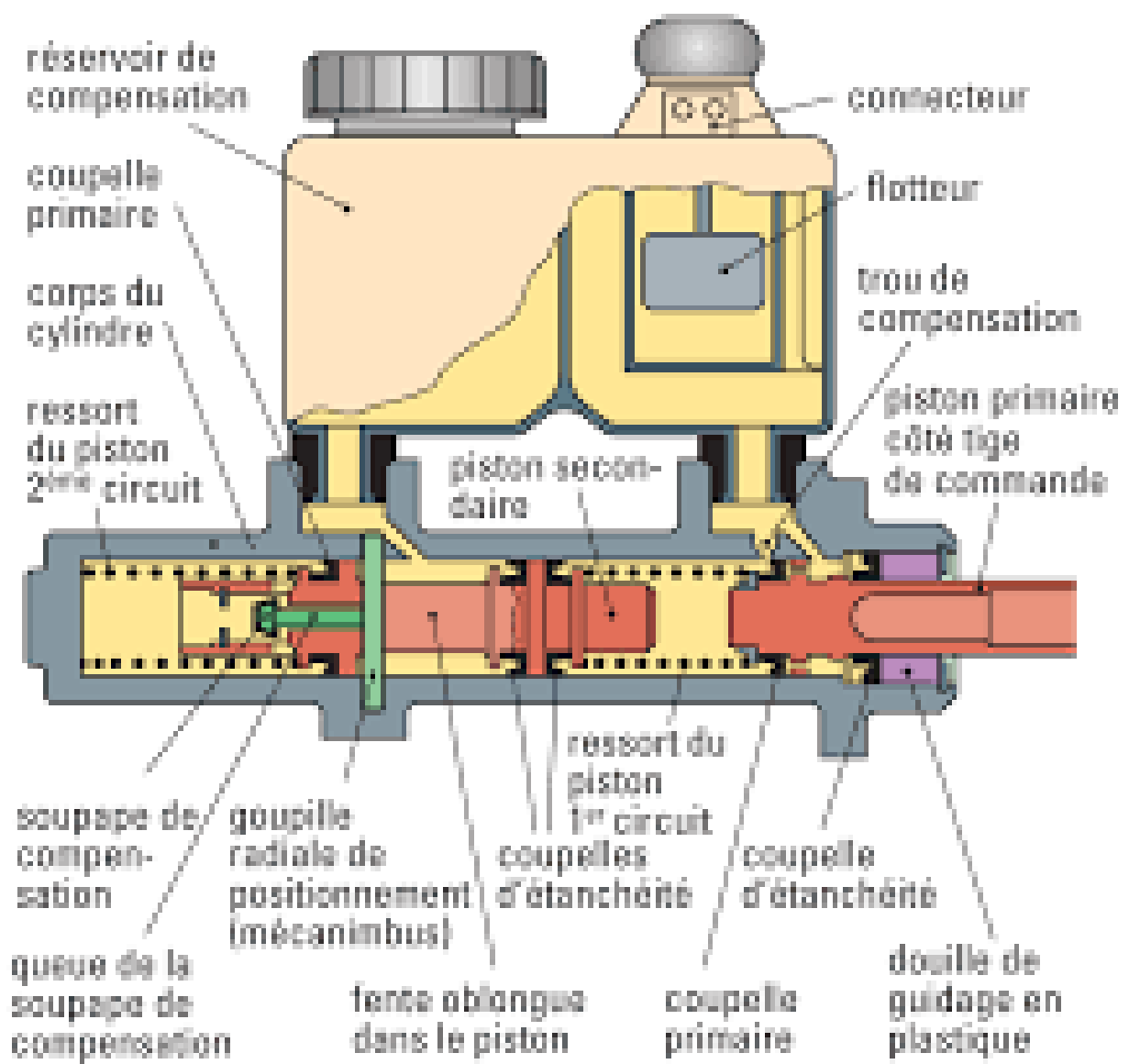


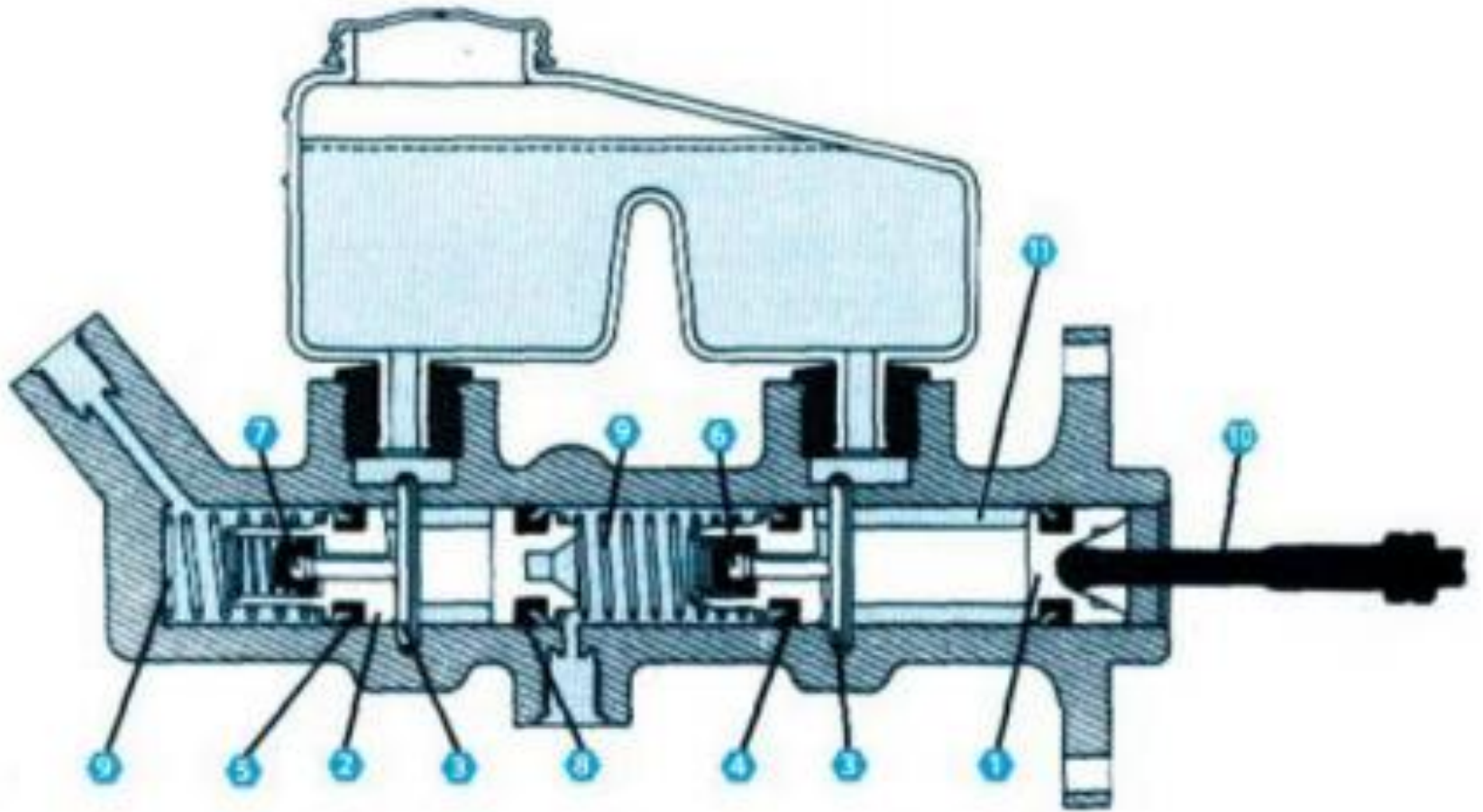






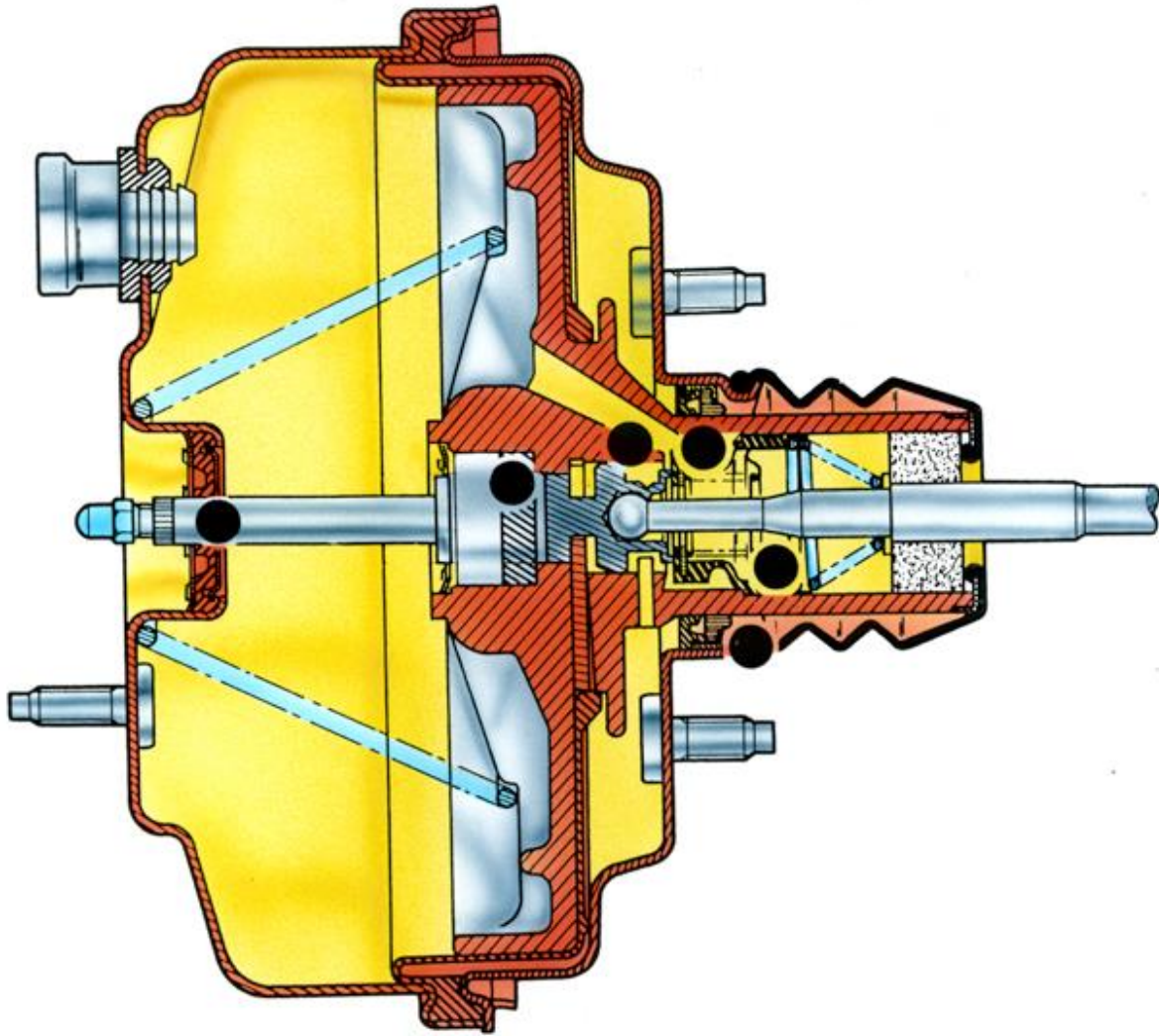


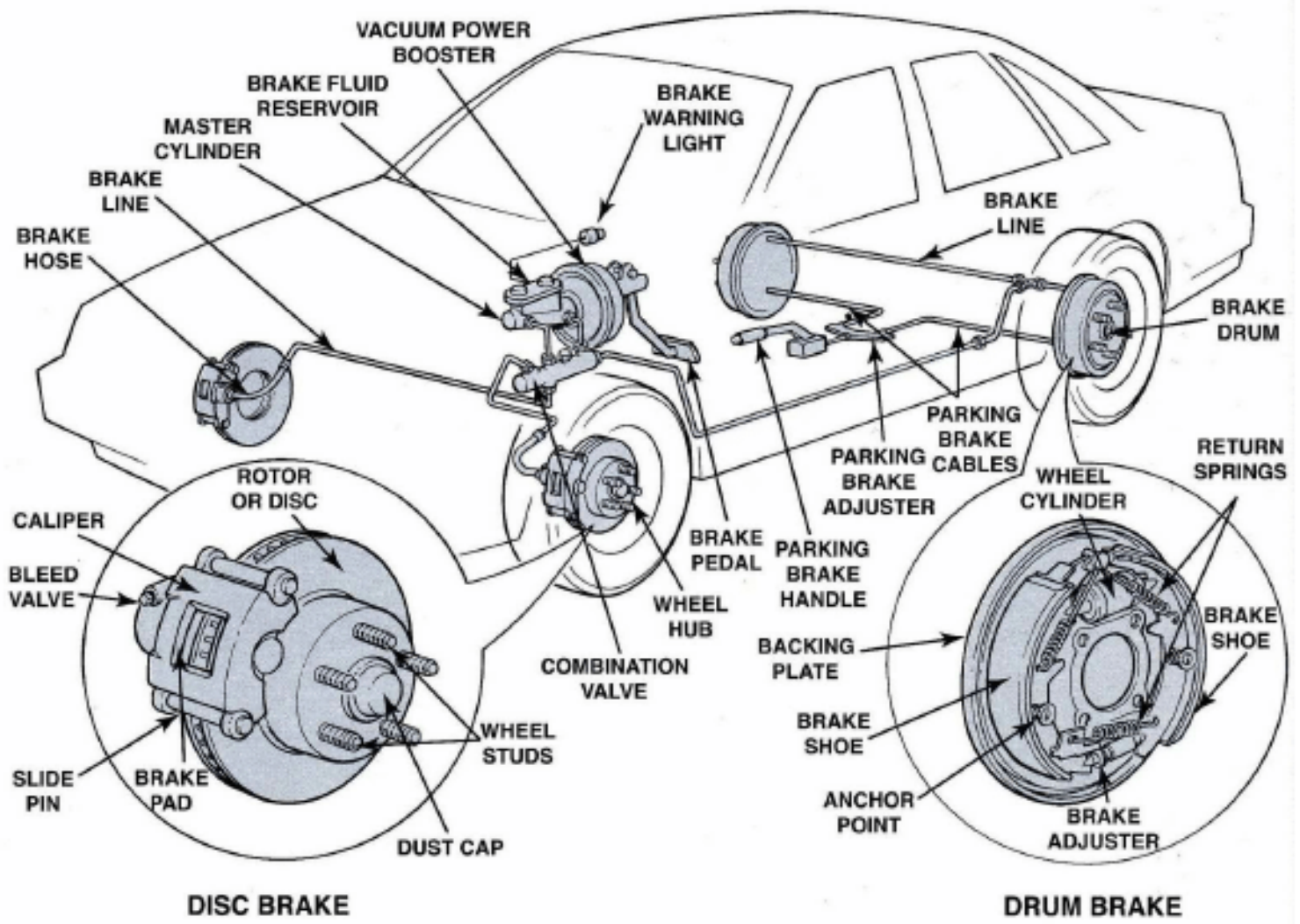


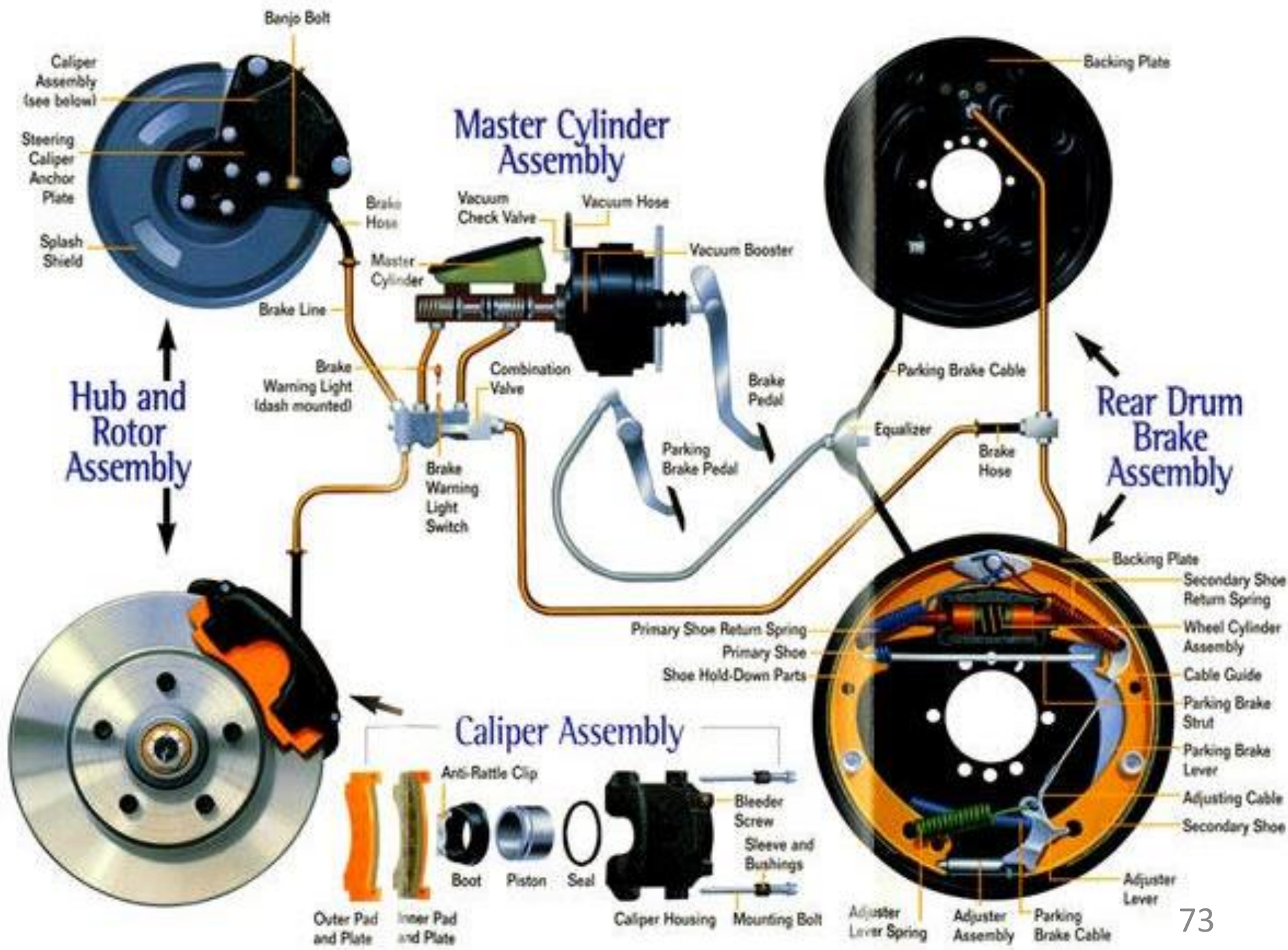












# Automotive Braking System

